

LCV 100W 24V DALI DT8 TW SR
LED Driver Constant Voltage 24V DALI-2 DT8 Tunable White



Highlights

- Independent digital dimmable LED-driver for constant voltage 24 VDC
- Supports DALI-2 specification (IEC 62386-209:2018)
- DALI Device Type 8 for Tunable White applications
- Use a single DALI-address for dual colour LED-strips
- DALI address can easily be set with integrated display (no programming needed)
- High resolution dimming range 0.1 – 100 %
- Max. output power 100 W (24 VDC)
- Typ. efficiency > 90 %
- Nominal life-time up to 50,000 h
- 5-year warranty

Applications

- General Lighting
- Linear Lighting
- Accent Lighting
- Furniture Lighting

Housing

- Polycarbonate White/Cyan
- Built-in strain relief on primary side
- Screw Terminals 0.5 - 2.5 mm²
- Integrated DALI-address selector and display
- Type of protection IP20

Technical data

Rated supply voltage, AC ①	100 – 240 VAC
AC voltage range	90 – 277 VAC
Mains frequency	47 – 63 Hz
Typ. current (at 230 V, 50 Hz, full load)	500 mA
Max input power	115 W
Typ. efficiency (at 230 V / 50 Hz / full load) ②	90%
λ (at 230 V, 50 Hz, full load)	0.985
Typ. power input on stand-by ③	3.4 W
Typ. input current in no-load operation	29 mA
In-rush current (peak / duration)	80 A / μs
Mains surge capability (between L – N)	2 kV
THD (at 230 V, 50 Hz, full load)	< 10 %
Time to light (at 230 V, 50 Hz, full load)	< 2 s
Turn off time (at 230 V, 50 Hz, full load)	< 0,8 s
Output voltage tolerance	0,5 VDC
Output LF voltage ripple (< 120 Hz)	3 %
Max. output voltage (no-load voltage)	24,6 VDC
Dimming frequency (PWM)	500 Hz
No of dimming channels	2
Max Load per driver	4,16 A
Min Load per driver	0,2 A
Asymmetric load permitted	Yes
No-load operation permitted	Yes
Dimming range	0.1 – 100 %
DALI-mode	DT8-Tc
DALI Short Addresses	1
DALI Current Draw	2 mA
Ambient temperature, ta	-20...+45 °C
Max. casing temperature, tc	75 °C
Humidity	20 – 90 %
Storage temperature	-40...+80 °C
Weight	440 g
Dimensions LxWxH	244 x 64 x 32 mm

① Valid at 100 % dimming level
 ② Depending on the DALI traffic at the interface
 ③ Operating outside the supply voltage window leads to an overload of the driver. This may result in a significant reduction in lifetime or even destruction of the dimmer.



Standards

→ page 2

Dimming Control Interfaces

- Single addressable DALI short address
- DALI-2 DT8 (according to EN 62386-209:2018)
- Colour Temperature control (Tc)
- Intensity control (dim level)

→ page 2

Manual & Installation Guidelines

→ page 3

Ordering data

Type	Article code	Packaging Carton	Packaging Pallet
LCV 100W 24V DALI DT8 TW SR	W7101-TW	20	200

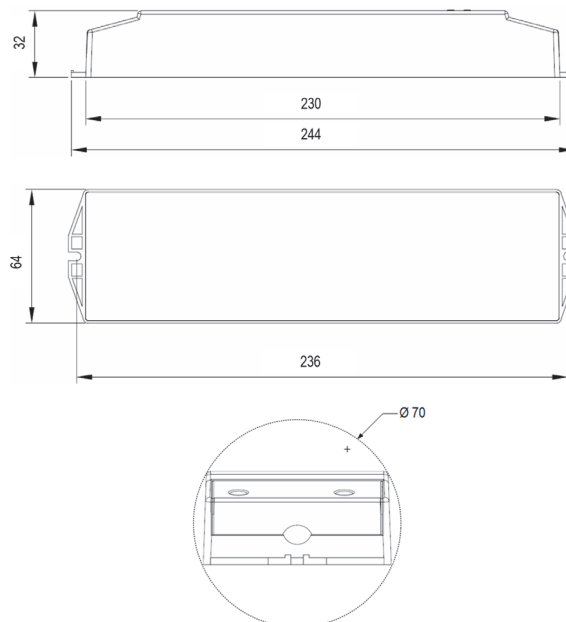

Standards

- EN 55015
- EN 61000-3-2
- EN 61000-3-3
- EN 61347-1
- EN 61347-2-13
- EN 61547
- EN 62386-101
- EN 62386-102
- EN 62386-207
- EN 62386-209

Thermal behaviour

Storage Temperature	-30/+80 °C
Operating Temperature	-30/+45 °C
Tc max	75 °C

Life-time

Ambient Temperature (Ta)	Reference Temperature (Tc)	Life-time
25 °C	55 °C	> 80,000 h
30 °C	60 °C	> 70,000 h
35 °C	65 °C	> 60,000 h
45 °C	75 °C	50,000 h

The LED Driver is designed for a life-time stated above under reference conditions and with a failure probability of less than 10 %. The relation of tc to ta temperature depends on the installation conditions.

⚠ The temperature on the reference point of the LED Driver (tc) may under no circumstances be higher than 75 °C if the expected lifetime of the dimmer is to be met.



Compliance with the maximum permissible reference temperature at the tc point must be checked under operating conditions in a thermally stable state. The maximum value must be determined under worst-case conditions for the relevant application.

Dimming

DIMMING CHARACTERISTICS

Dimming curve is adapted to the eye sensitiveness (logarithmic dimming). Dimming is realized by pulse width modulation dimming (500 Hz).

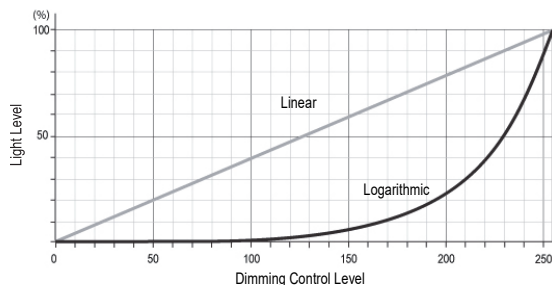

Dimming parameters can be changed using Tridonic masterCONFIGURATOR software.

	Programmable range (16 bit)	Default Value
Speed Min – Max	0.2 – 90 s	3 s
Fade Min – Max	0.2 – 90 s	1 s
Min Level	0.1 – 100 %	1 %
Max Level	100 – 1 %	100 %

DALI

Digital DALI signal should be wired on the terminals DA and DA. The DALI-terminals are located on the primary side (left). The control input is non-polar. The control signal is not SELV. Control cable must be installed in accordance to the requirements of low voltage installations.

With appropriate DALI-software and a programming interface the DALI channel can be addressed and various parameters can be configured in the LED Driver. Weilight recommend using Tridonic (www.tridonic) DALI-USB programmer and the software masterCONFIGURATOR. The LED Driver is recognized as a DALI-2 Device Type 8 for Colour Temperature Control as per the DALI Standard.

For further details see Manual & Installation Guidelines.

Range and asymmetric load

The LED Driver supports asymmetric load between the output channels on the secondary side if the total load per driver is ≥ 0.2 A and $\leq 4,16$ A.

Wire type and cross section

Stranded wire or solid wire up to 2.5 mm² may be used for wiring. Strip 6-7 mm of insulation from the cables to ensure perfect operation of the push terminals. Use one wire for each terminal connector only. For the strain relief to work properly the outer dimension of the cable should be between 7 – 12 mm. The LED wiring should be kept as short as possible to ensure good EMC. If the secondary cable length is longer than 2 m (4 m circuit), it is recommended to use a screened cable type, e.g. LiYCY 3 x 2.5 mm².

Calculating Voltage Drop

When calculating the recommended cable area for your low-voltage connections the maximum permitted voltage drop is 1 V. Please make sure you consider the total length, i.e. including the length of your LED-strip in your voltage drop calculation.

Secondary switching & Hot plug-in

Secondary switching and hot plug-in is not allowed due to the risk of arcing effects on the secondary side which can lead to malfunction or irreparable damage.

Maximum loading of automatic circuit breakers

Type	C10	C13	C16	C20
Max no of Drivers	16	20	26	32

Electrical Protection & Troubleshooting

NO-LOAD OPERATION

The LED Driver will not be damaged in no-load operation. The output will be deactivated and is therefore free of voltage. If a LED load is connected the device must be restarted before the output will be activated again.

SHORT-CIRCUIT BEHAVIOUR

In case of a short-circuit at the LED output the LED is switched off. After restart of the LED Driver the output will be activated again. The restart can either be done via supply voltage reset or DALI.

VOLTAGE PROTECTION

If the supply voltage range is outside the range 100-240 VAC the LED Driver turns off the LED output. After restart of the LED Driver the output will be activated again. The restart can either be done via supply voltage reset or DALI.

OVERLOAD PROTECTION

If the connected load per channel is $> 4,16$ A and/or the total load per driver is < 0.2 A or $> 4,16$ A the LED Driver turns off the LED output. After restart of the LED Driver the output will be activated again. The restart can either be done via supply voltage reset or DALI.

OVERTEMPERATURE PROTECTION

The LED Driver is protected against temporary thermal overheating. If the temperature limit is exceeded the LED module(s) are dimmed to reduce operating temperature. The temperature protection is activated above to max.

Manual & Installation Guidelines

Electrical connections



! Always disconnect mains before connecting the LED to the driver

Terminal	Connection	Details
N L	Mains supply	100-240 VAC
DA	DALI signal	0±4.5 V for "0" and 16±6.5 V for "1"
+	LED Output	24 VDC Common +
WW -	LED Output	24 VDC Warm White LED -
CW -	LED Output	24 VDC Cool White LED -
NC	Not in use	

Setting the DALI-address

If you want to set the DALI-address via software, please refer to your DALI-software manual to set the DALI-address of the driver, e.g. Tridonic masterCONFIGURATOR software available from tridonic.com.

If you want to set the DALI-address manually, please follow the instructions below. The address can be set to any number between 01-64.



1. Make sure the driver is connected to mains supply. Press and hold the left button below until the display starts flashing then release the button.



2. Click on the left button to set the first digit (ten position) in the DALI-address, i.e. any number from 0-6.



Example; to set the DALI-address 25, click the left button until the digit 2 is shown in the display.

3. Click on the right button to set the second position in the DALI-address, i.e. any number from 0-9.



Example; to set the DALI-address 25, click the right button until the digit 5 is shown in the display.

4. Press and hold down any button until the display stops flashing to store the setting into the driver.



Tunable White configuration

The optimal way to control tunable white LED is with a DALI DT8 compatible driver. With this method one colour temperature is transmitted directly to the driver. The advantage here is that the colour temperatures are not calculated in the driver. Colour temperatures can be controlled relative to the output value.

For example, the brightness can be controlled by using Welight's rotary dimmer (code W7400-DT8-TW). Double-click on the knob to switch between controlling the dim level and colour temperature. Since the driver has already been adjusted to the primary colours of the dual white LED, tunable white LEDtapes can be controlled in a user-friendly manner.

For your tunable white application to work properly it is important to set the LED specific values with the Tridonic masterCONFIGURATOR software. The colour temperature range can be set, and colours can be directly changed in the Colour tab.

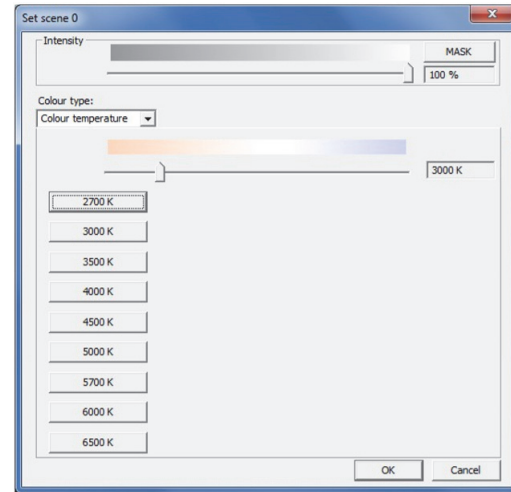

COLOUR TEMPERATURE RANGE

The range in which the colour temperature of the LED can be changed can be programmed via software. The colour temperature range is restricted to the physical upper and lower limits.

- **Minimum colour temperature:** the warmest colour temperature that your LED can have. This temperature is either the physical lower limit or is cooler than this limit.
- **Maximum colour temperature:** the coolest colour temperature that your LED can have. This temperature is either the physical upper limit or is warmer than this limit.
- **Physical lower limit:** Allows the LED driver to be adjusted to the colour temperature limits of the connected LED module.
- **Physical upper limit:** Allows the LED driver to be adjusted to the colour temperature limits of the connected LED module.

Note! The physical lower limit and the physical upper limit can only be adjusted if an LED module is connected to the device and switched on.

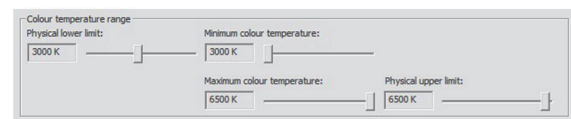

1. Set the value for the individual parameter using the slider.
2. Click on save. Changes are stored in the driver.

Note! The minimum colour temperature cannot be lower than the physical lower limit. The maximum colour temperature cannot be higher than the physical upper limit.

EXAMPLE

Using the driver together with welight tunable white W1004-series any colour temperature between 2000 K and 6500 K can be generated via DALI.

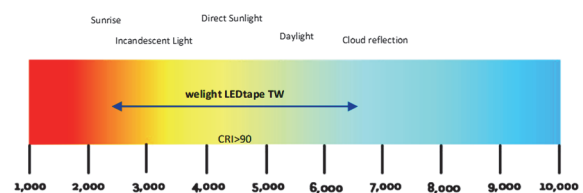

SAFETY INSTRUCTIONS

- EN** Read these instructions carefully before starting the installation and save for future reference. All connections to the device must be made by a qualified electrician or person with the necessary expertise in electrical installation in accordance with relevant rules and standards. Make sure that the mains voltage is disconnected before installation or maintenance.
- SE** Läs dessa instruktioner innan installationen påbörjas och lämna dem vidare till brukaren av anläggningen. All anslutning till enheten får endast utföras av behörig elektriker eller person med kännedom om elektrisk installation i enlighet med gällande regler och standard. Se till att spänningen är frånslagen före installation eller underhåll.
- FI** Lue nämä ohjeet ennen asentamista ja luovuta ohjeet valaisimen seuraavalle käyttäjälle. Kytkenät ohjaimen saa tehdä ainoastaan pätevä sähköasentaja tai sähköasennukset hallitseva henkilö voimassa olevien määräysten ja standardien mukaisesti. Varmista, että jännite on kytketty päältä ennen asennusta ja huoltoa.
- NO** Les disse instruksjonene før du starter installeringen, og gi den deretter videre til anleggets bruker. All tilkobling til enheten skal utføres av godkjent elektriker eller person med nødvendig kunnskap om elektrisk installasjon i henhold til gjeldende forskrifter og standard. Sørg for at strømmen er koblet fra før installering og ved vedlikehold.
- DK** Læs disse anvisninger før du starter installationen og aflever vejledningen til anlæggets bruger. Alle tilslutninger på enheden skal udføres af en autoriseret elinstallatør i overensstemmelse med gældende regler og standarder. Afbryd spænding før installation og vedligeholdelse.