

**Module LLE 16mm 1250lm HV ADV5**

Modules LLE advanced



LLE 16x70mm 325lm HV ADV5



LLE 16x140mm 650lm HV ADV5



LLE 16x280mm 1250lm HV ADV5

**Product description**

- \_ Ideal for compact linear luminaire designs
- \_ Homogenous illumination thanks to small package distance
- \_ 2 terminals for serial wiring
- \_ Perfectly uniform light, even if several LED modules are used together in a line
- \_ Push terminals for quick and simple wiring of LED module to LED module
- \_ HE ... High Efficiency, NM ... Nominal Mode, HO ... High Output
- \_ Min. order quantity LLE 16x70mm 325lm 8xx HV ADV5 QTY4: 32 pcs. The LLE 16x70mm 325lm 8xx HV ADV5 module contains 4 single 16x70mm modules which have to be separated.
- \_ Long lifetime up to 72,000 hours
- \_ 5 years guarantee (conditions at <https://www.tridonic.com/manufacturer-guarantee-conditions>)

**Optical properties**

- \_ Colour temperatures 2,700, 3,000, 3,500, 4,000, 5,000 and 6,500 K
- \_ Useful luminous flux 2,508 lm at Irated and tp = 25 °C
- \_ Efficacy of the LED module 195 lm/W at Irated and tp = 25 °C
- \_ High colour rendering index CRI > 80
- \_ High colour consistency (MacAdam 3) ①
- \_ Small luminous flux tolerances

**Mechanical properties**

- \_ Module dimension 16 x 70 mm, 16 x 140 mm, 16 x 280 mm and 16 x 560 mm
- \_ Simple installation via clips or screws

**System solution**

- \_ Combine Tridonic's LED modules and dimmable drivers to achieve an outstanding system efficacy (configuration possible via <https://setbuilder.tridonic.com/>)

① Integral measurement over the complete module.

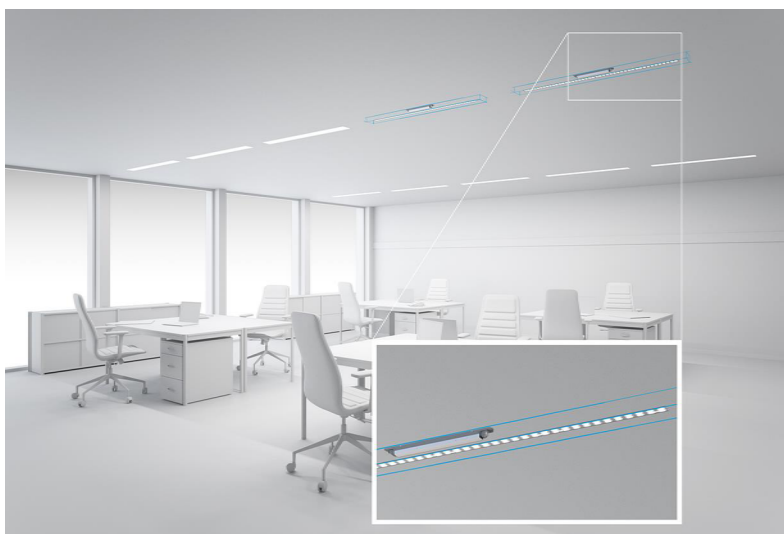
**Website**<http://www.tridonic.com/89603400>

Spotlights



Downlights



Linear



Area



Floor | Wall



Free-standing



Street



Decorative



High bay

**Module LLE 16mm 1250lm HV ADV5**

Modules LLE advanced

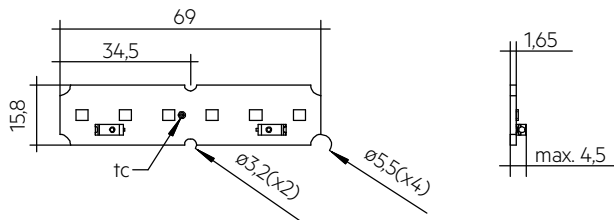

LLE 16x70mm 325lm HV ADV5

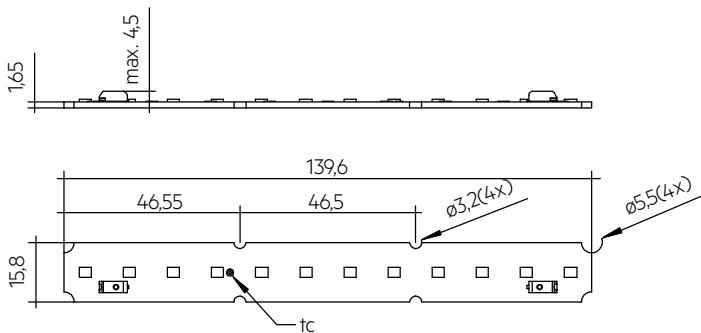

LLE 16x140mm 650lm HV ADV5

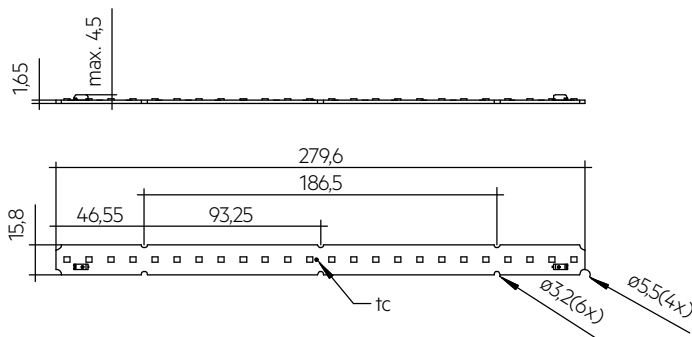

LLE 16x280mm 1250lm HV ADV5

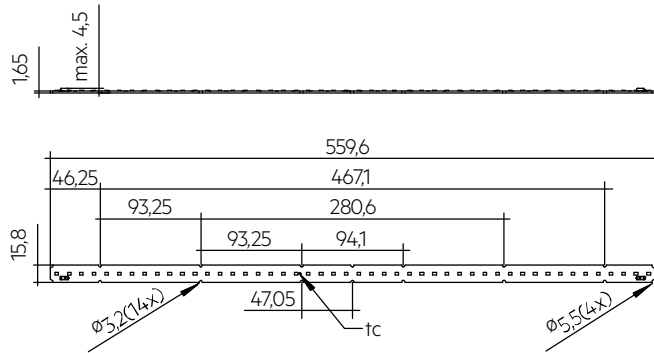

LLE 16x560mm 2400lm HV ADV5

**Ordering data**

Type	Article number	Article status	Colour temperature	Packaging, carton	Weight per pc.
LLE 16x70mm 325lm 830 HV ADV5 QTY4	89603400	On demand	3,000 K	144 pc(s).	0.017 kg
LLE 16x70mm 325lm 840 HV ADV5 QTY4	89603401	Standard	4,000 K	144 pc(s).	0.017 kg
LLE 16x140mm 650lm 827 HV ADV5	89603402	Standard	2,700 K	144 pc(s).	0.007 kg
LLE 16x140mm 650lm 830 HV ADV5	89603403	Standard	3,000 K	144 pc(s).	0.007 kg
LLE 16x140mm 650lm 835 HV ADV5	28003994	On demand	3,500 K	144 pc(s).	0.007 kg
LLE 16x140mm 650lm 840 HV ADV5	89603404	Standard	4,000 K	144 pc(s).	0.007 kg
LLE 16x140mm 650lm 850 HV ADV5	89603405	On demand	5,000 K	144 pc(s).	0.007 kg
LLE 16x140mm 650lm 865 HV ADV5	89603406	On demand	6,500 K	144 pc(s).	0.007 kg
LLE 16x280mm 1250lm 827 HV ADV5	89603407	Standard	2,700 K	144 pc(s).	0.014 kg
LLE 16x280mm 1250lm 830 HV ADV5	89603408	Standard	3,000 K	144 pc(s).	0.014 kg
LLE 16x280mm 1250lm 835 HV ADV5	28003995	On demand	3,500 K	144 pc(s).	0.014 kg
LLE 16x280mm 1250lm 840 HV ADV5	89603409	Standard	4,000 K	144 pc(s).	0.014 kg
LLE 16x280mm 1250lm 850 HV ADV5	89603410	On demand	5,000 K	144 pc(s).	0.014 kg
LLE 16x280mm 1250lm 865 HV ADV5	89603411	Standard	6,500 K	144 pc(s).	0.014 kg
LLE 16x560mm 2400lm 827 HV ADV5	89603412	Standard	2,700 K	144 pc(s).	0.028 kg
LLE 16x560mm 2400lm 830 HV ADV5	89603413	Standard	3,000 K	144 pc(s).	0.028 kg
LLE 16x560mm 2400lm 835 HV ADV5	28003996	On demand	3,500 K	144 pc(s).	0.028 kg
LLE 16x560mm 2400lm 840 HV ADV5	89603414	Standard	4,000 K	144 pc(s).	0.028 kg
LLE 16x560mm 2400lm 850 HV ADV5	89603415	On demand	5,000 K	144 pc(s).	0.028 kg
LLE 16x560mm 2400lm 865 HV ADV5	89603416	Standard	6,500 K	144 pc(s).	0.028 kg

**Technical data**

Beam characteristic	120°
Ambient temperature $t_a$	-40 ... +65 °C
$t_p$ rated	50 °C
$t_c$	85 °C
$I_{rated}$	300 mA
$I_{max}$	540 mA
Max. permissible LF current ripple	595 mA
Max. permissible peak current	900 mA / max. 8 ms
Max. working voltage for insulation <sup>®</sup>	400 V
Insulation test voltage	1.8 kV
CTI of the printed circuit board	≥ 600
ESD classification	Severity level 4
Risk group (IEC 62471) at ≤ 470 mA	RG0
Risk group (IEC 62471) at $I_{max}$	RG1
Classification acc. to IEC 62031	Built-in
Type of protection	IP00
Lumen maintenance L70B50	72,000 h
Guarantee (conditions at <a href="http://www.tridonic.com">www.tridonic.com</a> )	5 Year(s)

**Approval marks****Standards**

IEC 62031, IEC 62471, IEC 61000-4-2, IEC 62778, IEC 61547, UL 8750

## Specific technical data

Type	Article number	Photometric code	Useful luminous flux at tp = 25 °C <sup>②</sup>	Expected luminous flux at tp rated <sup>③</sup>	Typ. forward current	Min. forward voltage at tp rated	Max. forward voltage at tp = 25 °C	Power consumption <sup>④</sup> Pon at tp = 25 °C	Efficacy of the module at tp = 25 °C	Expected efficacy of the module at tp rated	Colour rendering index CRI
<b>Operating mode HE at 200 mA</b>											
LLE 16x70mm 325lm 830 HV ADV5 QTY4	89603400	830/359	-	201 lm	200 mA	5.1 V	5.7 V	-	-	183 lm/W	>>80
LLE 16x70mm 325lm 840 HV ADV5 QTY4	89603401	840/359	-	217 lm	200 mA	5.1 V	5.7 V	-	-	197 lm/W	>>80
LLE 16x140mm 650lm 827 HV ADV5	89603402	827/359	-	384 lm	200 mA	10.2 V	11.4 V	-	-	180 lm/W	>>80
LLE 16x140mm 650lm 830 HV ADV5	89603403	830/359	-	408 lm	200 mA	10.2 V	11.4 V	-	-	191 lm/W	>>80
LLE 16x140mm 650lm 835 HV ADV5	28003994	835/359	-	419 lm	200 mA	10.2 V	11.4 V	-	-	190 lm/W	>>80
LLE 16x140mm 650lm 840 HV ADV5	89603404	840/359	-	434 lm	200 mA	10.2 V	11.4 V	-	-	203 lm/W	>>80
LLE 16x140mm 650lm 850 HV ADV5	89603405	850/359	-	420 lm	200 mA	10.2 V	11.4 V	-	-	191 lm/W	>>80
LLE 16x140mm 650lm 865 HV ADV5	89603406	865/359	-	421 lm	200 mA	10.2 V	11.4 V	-	-	191 lm/W	>>80
LLE 16x280mm 1250lm 827 HV ADV5	89603407	827/359	-	770 lm	200 mA	20.4 V	22.7 V	-	-	177 lm/W	>>80
LLE 16x280mm 1250lm 830 HV ADV5	89603408	830/359	-	819 lm	200 mA	20.4 V	22.7 V	-	-	189 lm/W	>>80
LLE 16x280mm 1250lm 835 HV ADV5	28003995	835/359	-	838 lm	200 mA	20.4 V	22.7 V	-	-	195 lm/W	>>80
LLE 16x280mm 1250lm 840 HV ADV5	89603409	840/359	-	870 lm	200 mA	20.4 V	22.7 V	-	-	199 lm/W	>>80
LLE 16x280mm 1250lm 850 HV ADV5	89603410	850/359	-	848 lm	200 mA	20.4 V	22.7 V	-	-	197 lm/W	>>80
LLE 16x280mm 1250lm 865 HV ADV5	89603411	865/359	-	849 lm	200 mA	20.4 V	22.7 V	-	-	197 lm/W	>>80
LLE 16x560mm 2400lm 827 HV ADV5	89603412	827/359	-	1,585 lm	200 mA	40.9 V	45.3 V	-	-	184 lm/W	>>80
LLE 16x560mm 2400lm 830 HV ADV5	89603413	830/359	-	1,620 lm	200 mA	40.9 V	45.3 V	-	-	188 lm/W	>>80
LLE 16x560mm 2400lm 835 HV ADV5	28003996	835/359	-	1,677 lm	200 mA	40.9 V	45.3 V	-	-	193 lm/W	>>80
LLE 16x560mm 2400lm 840 HV ADV5	89603414	840/359	-	1,701 lm	200 mA	40.9 V	45.3 V	-	-	196 lm/W	>>80
LLE 16x560mm 2400lm 850 HV ADV5	89603415	850/359	-	1,698 lm	200 mA	40.9 V	45.3 V	-	-	195 lm/W	>>80
LLE 16x560mm 2400lm 865 HV ADV5	89603416	865/359	-	1,698 lm	200 mA	40.9 V	45.3 V	-	-	195 lm/W	>>80
<b>Operating mode NM at 300 mA</b>											
LLE 16x70mm 325lm 830 HV ADV5 QTY4	89603400	830/359	302 lm	291 lm	300 mA	5.2 V	5.8 V	1.7 W	178 lm/W	171 lm/W	>>80
LLE 16x70mm 325lm 840 HV ADV5 QTY4	89603401	840/359	321 lm	311 lm	300 mA	5.2 V	5.8 V	1.7 W	189 lm/W	185 lm/W	>>80
LLE 16x140mm 650lm 827 HV ADV5	89603402	827/359	568 lm	558 lm	300 mA	10.4 V	11.6 V	3.3 W	172 lm/W	169 lm/W	>>80
LLE 16x140mm 650lm 830 HV ADV5	89603403	830/359	604 lm	589 lm	300 mA	10.4 V	11.6 V	3.3 W	183 lm/W	180 lm/W	>>80
LLE 16x140mm 650lm 835 HV ADV5	28003994	835/359	620 lm	604 lm	300 mA	10.4 V	11.6 V	3.3 W	188 lm/W	183 lm/W	>>80
LLE 16x140mm 650lm 840 HV ADV5	89603404	840/359	643 lm	628 lm	300 mA	10.4 V	11.6 V	3.3 W	195 lm/W	191 lm/W	>>80
LLE 16x140mm 650lm 850 HV ADV5	89603405	850/359	627 lm	607 lm	300 mA	10.4 V	11.6 V	3.3 W	190 lm/W	184 lm/W	>>80
LLE 16x140mm 650lm 865 HV ADV5	89603406	865/359	627 lm	607 lm	300 mA	10.4 V	11.6 V	3.3 W	190 lm/W	184 lm/W	>>80
LLE 16x280mm 1250lm 827 HV ADV5	89603407	827/359	1,133 lm	1,104 lm	300 mA	20.8 V	23.1 V	6.7 W	169 lm/W	166 lm/W	>>80
LLE 16x280mm 1250lm 830 HV ADV5	89603408	830/359	1,213 lm	1,183 lm	300 mA	20.8 V	23.1 V	6.7 W	181 lm/W	178 lm/W	>>80
LLE 16x280mm 1250lm 835 HV ADV5	28003995	835/359	1,240 lm	1,207 lm	300 mA	20.8 V	23.1 V	6.7 W	185 lm/W	183 lm/W	>>80
LLE 16x280mm 1250lm 840 HV ADV5	89603409	840/359	1,282 lm	1,252 lm	300 mA	20.8 V	23.1 V	6.7 W	191 lm/W	187 lm/W	>>80
LLE 16x280mm 1250lm 850 HV ADV5	89603410	850/359	1,254 lm	1,224 lm	300 mA	20.8 V	23.1 V	6.7 W	187 lm/W	185 lm/W	>>80
LLE 16x280mm 1250lm 865 HV ADV5	89603411	865/359	1,254 lm	1,224 lm	300 mA	20.8 V	23.1 V	6.7 W	187 lm/W	185 lm/W	>>80
LLE 16x560mm 2400lm 827 HV ADV5	89603412	827/359	2,343 lm	2,283 lm	300 mA	41.7 V	46.2 V	13.3 W	176 lm/W	173 lm/W	>>80
LLE 16x560mm 2400lm 830 HV ADV5	89603413	830/359	2,400 lm	2,332 lm	300 mA	41.7 V	46.2 V	13.3 W	180 lm/W	178 lm/W	>>80
LLE 16x560mm 2400lm 835 HV ADV5	28003996	835/359	2,480 lm	2,413 lm	300 mA	41.7 V	46.2 V	13.3 W	186 lm/W	183 lm/W	>>80
LLE 16x560mm 2400lm 840 HV ADV5	89603414	840/359	2,508 lm	2,440 lm	300 mA	41.7 V	46.2 V	13.3 W	189 lm/W	185 lm/W	>>80
LLE 16x560mm 2400lm 850 HV ADV5	89603415	850/359	2,508 lm	2,448 lm	300 mA	41.7 V	46.2 V	13.3 W	189 lm/W	185 lm/W	>>80
LLE 16x560mm 2400lm 865 HV ADV5	89603416	865/359	2,508 lm	2,448 lm	300 mA	41.7 V	46.2 V	13.3 W	189 lm/W	185 lm/W	>>80
<b>Operating mode HO at 500 mA</b>											
LLE 16x70mm 325lm 830 HV ADV5 QTY4	89603400	830/359	-	472 lm	500 mA	5.3 V	6.0 V	-	-	169 lm/W	>>80
LLE 16x70mm 325lm 840 HV ADV5 QTY4	89603401	840/359	-	499 lm	500 mA	5.3 V	6.0 V	-	-	173 lm/W	>>80
LLE 16x140mm 650lm 827 HV ADV5	89603402	827/359	-	893 lm	500 mA	10.7 V	11.9 V	-	-	158 lm/W	>>80
LLE 16x140mm 650lm 830 HV ADV5	89603403	830/359	-	948 lm	500 mA	10.7 V	11.9 V	-	-	168 lm/W	>>80
LLE 16x140mm 650lm 835 HV ADV5	28003994	835/359	-	973 lm	500 mA	10.7 V	11.9 V	-	-	171 lm/W	>>80
LLE 16x140mm 650lm 840 HV ADV5	89603404	840/359	-	1,007 lm	500 mA	10.7 V	11.9 V	-	-	179 lm/W	>>80
LLE 16x140mm 650lm 850 HV ADV5	89603405	850/359	-	979 lm	500 mA	10.7 V	11.9 V	-	-	172 lm/W	>>80
LLE 16x140mm 650lm 865 HV ADV5	89603406	865/359	-	979 lm	500 mA	10.7 V	11.9 V	-	-	172 lm/W	>>80
LLE 16x280mm 1250lm 827 HV ADV5	89603407	827/359	-	1,782 lm	500 mA	21.5 V	23.8 V	-	-	156 lm/W	>>80
LLE 16x280mm 1250lm 830 HV ADV5	89603408	830/359	-	1,903 lm	500 mA	21.5 V	23.8 V	-	-	166 lm/W	>>80
LLE 16x280mm 1250lm 835 HV ADV5	28003995	835/359	-	1,946 lm	500 mA	21.5 V	23.8 V	-	-	171 lm/W	>>80
LLE 16x280mm 1250lm 840 HV ADV5	89603409	840/359	-	2,017 lm	500 mA	21.5 V	23.8 V	-	-	176 lm/W	>>80
LLE 16x280mm 1250lm 850 HV ADV5	89603410	850/359	-	1,974 lm	500 mA	21.5 V	23.8 V	-	-	173 lm/W	>>80
LLE 16x280mm 1250lm 865 HV ADV5	89603411	865/359	-	1,974 lm	500 mA	21.5 V	23.8 V	-	-	173 lm/W	>>80
LLE 16x560mm 2400lm 827 HV ADV5	89603412	827/359	-	3,679 lm	500 mA	43.1 V	47.6 V	-	-	162 lm/W	>>80
LLE 16x560mm 2400lm 830 HV ADV5	89603413	830/359	-	3,766 lm	500 mA	43.1 V	47.6 V	-	-	166 lm/W	>>80
LLE 16x560mm 2400lm 835 HV ADV5	28003996	835/359	-	3,892 lm	500 mA	43.1 V	47.6 V	-	-	171 lm/W	>>80
LLE 16x560mm 2400lm 840 HV ADV5	89603414	840/359	-	3,937 lm	500 mA	43.1 V	47.6 V	-	-	173 lm/W	>>80
LLE 16x560mm 2400lm 850 HV ADV5	89603415	850/359	-	3,939 lm	500 mA	43.1 V	47.6 V	-	-	174 lm/W	>>80
LLE 16x560mm 2400lm 865 HV ADV5	89603416	865/359	-	3,940 lm	500 mA	43.1 V	47.6 V	-	-	174 lm/W	>>80

② If mounted with M3 screws and plastic washers.

③ Tolerance of useful light flux - 0 % / + 15 %. Measurement uncertainty ± 10 %.

④ Tolerance of expected light flux - 0 % / + 15 %. Measurement uncertainty ± 10 %. Based on calculation.

⑤ Tolerance of power consumption Pon ± 10 %. Measurement uncertainty ± 5 %.

## ACL BRIDGE LLE16

Accessory

**Product description**

- \_ Clip for fixation for LLE16
- \_ Fast snap on mounting (for sheet thickness 0.5 – 1.0 mm)
- \_ For drilling hole 3 mm
- \_ Clip made of polycarbonate
- \_ Minimum sales quantity 200 pcs.

**Website**

<http://www.tridonic.com/28001035>

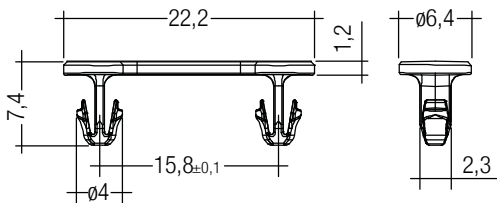
**Ordering data**

Type	Article number	Colour	Packaging, bag	Weight per pc.
ACL BRIDGE LLE16 PUSH-FIX	28001035	White	200 pc(s).	0.001 kg

## ACL LINEAR COVER 16mm

Accessory

**Product description**

- \_ LINEAR COVER for LLE 16
- \_ Protection against direct touch for non-SELV applications (recommendation: use all fixing points) <sup>①</sup>
- \_ Fast snap on mounting on to LLE 16 with clips or plastic washers
- \_ High transmission: transparent, semi-transparent and diffuse
- \_ Linear lense made of PMMA
- \_ Tolerances LINEAR COVER: + 10 mm for 1,600 / 1,200 mm length (ends raw)

① Ends must be covered by the luminaire construction.

**Website**

<http://www.tridonic.com/28000950>

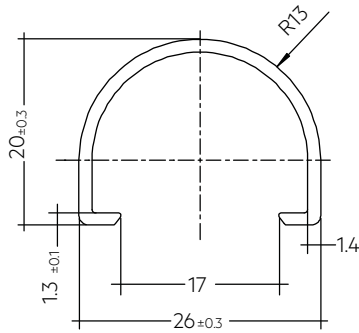
**Ordering data**

Type	Article number	Colour	Length L	Packaging, carton	Weight per pc.
ACL LINEAR COVER 16x1600mm FROSTED	28000950	Semi-transparent	1,600 mm	24 pc(s).	0.147 kg
ACL LINEAR COVER 16x1200mm FROSTED	28002827	Semi-transparent	1,200 mm	24 pc(s).	0.100 kg
ACL LINEAR COVER 16x1600mm DIFFUSE	28000951	Diffuse	1,600 mm	24 pc(s).	0.147 kg
ACL LINEAR COVER 16x1200mm DIFFUSE	28002828	Diffuse	1,200 mm	24 pc(s).	0.100 kg

## 1. Standards

IEC 62031  
 IEC 62471  
 IEC 61000-4-2  
 IEC 62778  
 IEC 61547  
 UL 8750 (for CLASS2 circuits and dry locations)

### 1.1 Photometric code

Key for photometric code, e. g. 830 / 349

1 <sup>st</sup> digit	2 <sup>nd</sup> + 3 <sup>rd</sup> digit	4 <sup>th</sup> digit	5 <sup>th</sup> digit	6 <sup>th</sup> digit	
Code CRI	Colour temperature in Kelvin x 100	MacAdam initial	MacAdam after 25% of the lifetime (max.6000h)	Luminous flux after 25% of the lifetime (max.6000h)	
7 70 – 79				Code	Luminous flux
8 80 – 89				7	≥ 70 %
9 ≥90				8	≥ 80 %
				9	≥ 90 %

### 1.2 Energy classification

Type	Colour temperature	Forward current	Energy classification	Energy consumption
LLE 16x70mm 325lm 830 HV ADV5 QTY4	3,000 K	300 mA	C	2 kWh / 1,000 h
LLE 16x70mm 325lm 840 HV ADV5 QTY4	4,000 K	300 mA	C	2 kWh / 1,000 h
LLE 16x140mm 650lm 827 HV ADV5	2,700 K	300 mA	D	4 kWh / 1,000 h
LLE 16x140mm 650lm 830 HV ADV5	3,000 K	300 mA	C	4 kWh / 1,000 h
LLE 16x140mm 650lm 835 HV ADV5	3,500 K	300 mA	C	4 kWh / 1,000 h
LLE 16x140mm 650lm 840 HV ADV5	4,000 K	300 mA	C	4 kWh / 1,000 h
LLE 16x140mm 650lm 850 HV ADV5	5,000 K	300 mA	C	4 kWh / 1,000 h
LLE 16x140mm 650lm 865 HV ADV5	6,500 K	300 mA	C	4 kWh / 1,000 h
LLE 16x280mm 1250lm 827 HV ADV5	2,700 K	300 mA	D	7 kWh / 1,000 h
LLE 16x280mm 1250lm 830 HV ADV5	3,000 K	300 mA	C	7 kWh / 1,000 h
LLE 16x280mm 1250lm 835 HV ADV5	3,500 K	300 mA	C	7 kWh / 1,000 h
LLE 16x280mm 1250lm 840 HV ADV5	4,000 K	300 mA	C	7 kWh / 1,000 h
LLE 16x280mm 1250lm 850 HV ADV5	5,000 K	300 mA	C	7 kWh / 1,000 h
LLE 16x280mm 1250lm 865 HV ADV5	6,500 K	300 mA	C	7 kWh / 1,000 h
LLE 16x560mm 2400lm 827 HV ADV5	2,700 K	300 mA	C	14 kWh / 1,000 h
LLE 16x560mm 2400lm 830 HV ADV5	3,000 K	300 mA	C	14 kWh / 1,000 h
LLE 16x560mm 2400lm 835 HV ADV5	3,500 K	300 mA	C	14 kWh / 1,000 h
LLE 16x560mm 2400lm 840 HV ADV5	4,000 K	300 mA	C	14 kWh / 1,000 h
LLE 16x560mm 2400lm 850 HV ADV5	5,000 K	300 mA	C	14 kWh / 1,000 h
LLE 16x560mm 2400lm 865 HV ADV5	6,500 K	300 mA	C	14 kWh / 1,000 h

Energy label and further information at [www.tridonic.com](http://www.tridonic.com) in the certificates tab of the corresponding product page and at the EPREL data base <https://eprel.ec.europa.eu/>

## 2. Thermal details

### 2.1 tc point, ambient temperature and lifetime

The temperature at tp reference point is crucial for the light output and lifetime of a LED product.

For LLE a tp temperature of 50 °C has to be complied in order to achieve an optimum between heat sink requirements, light output and lifetime.

Compliance with the maximum permissible reference temperature at the tc point must be checked under operating conditions in a thermally stable state. The maximum value must be determined under worst-case conditions for the relevant application.

The tc and tp temperature of LED modules from Tridonic are measured at the same reference point.

### 2.2 Storage and humidity

Storage temperature	-40...+85 °C
---------------------	--------------

Operation only in non condensing environment.

Humidity during processing of the module should be between 30 to 70 %.

### 2.3 Heat sink values

#### LLE 16x70mm 325lm ADV5

ta	tp	Forward current	R <sub>th, hs-a</sub>	Cooling area
25 °C	50 °C	300 mA	2972 K/W	22 cm <sup>2</sup>
25 °C	50 °C	500 mA	1587 K/W	42 cm <sup>2</sup>
35 °C	50 °C	300 mA	1782 K/W	37 cm <sup>2</sup>
35 °C	50 °C	500 mA	951 K/W	70 cm <sup>2</sup>
40 °C	50 °C	300 mA	1186 K/W	56 cm <sup>2</sup>
40 °C	50 °C	500 mA	632 K/W	105 cm <sup>2</sup>
45 °C	50 °C	300 mA	591 K/W	113 cm <sup>2</sup>
45 °C	50 °C	500 mA	314 K/W	212 cm <sup>2</sup>

#### LLE 16x140mm 650lm ADV5

ta	tp	Forward current	R <sub>th, hs-a</sub>	Cooling area
25 °C	50 °C	300 mA	1614 K/W	41 cm <sup>2</sup>
25 °C	50 °C	500 mA	864 K/W	77 cm <sup>2</sup>
35 °C	50 °C	300 mA	968 K/W	69 cm <sup>2</sup>
35 °C	50 °C	500 mA	518 K/W	129 cm <sup>2</sup>
40 °C	50 °C	300 mA	645 K/W	103 cm <sup>2</sup>
40 °C	50 °C	500 mA	344 K/W	194 cm <sup>2</sup>
45 °C	50 °C	300 mA	321 K/W	208 cm <sup>2</sup>
45 °C	50 °C	500 mA	171 K/W	389 cm <sup>2</sup>

#### LLE 16x280mm 1250lm ADV5

ta	tp	Forward current	R <sub>th, hs-a</sub>	Cooling area
25 °C	50 °C	300 mA	819 K/W	81 cm <sup>2</sup>
25 °C	50 °C	500 mA	436 K/W	153 cm <sup>2</sup>
35 °C	50 °C	300 mA	491 K/W	136 cm <sup>2</sup>
35 °C	50 °C	500 mA	261 K/W	255 cm <sup>2</sup>
40 °C	50 °C	300 mA	327 K/W	204 cm <sup>2</sup>
40 °C	50 °C	500 mA	174 K/W	383 cm <sup>2</sup>
45 °C	50 °C	300 mA	163 K/W	409 cm <sup>2</sup>
45 °C	50 °C	500 mA	086 K/W	771 cm <sup>2</sup>

#### LLE 16x560mm 2400lm ADV5

ta	tp	Forward current	R <sub>th, hs-a</sub>	Cooling area
25 °C	50 °C	300 mA	427 K/W	156 cm <sup>2</sup>
25 °C	50 °C	500 mA	225 K/W	296 cm <sup>2</sup>
35 °C	50 °C	300 mA	256 K/W	260 cm <sup>2</sup>
35 °C	50 °C	500 mA	135 K/W	494 cm <sup>2</sup>
40 °C	50 °C	300 mA	171 K/W	391 cm <sup>2</sup>
40 °C	50 °C	500 mA	090 K/W	742 cm <sup>2</sup>
45 °C	50 °C	300 mA	085 K/W	784 cm <sup>2</sup>
45 °C	50 °C	500 mA	045 K/W	1493 cm <sup>2</sup>

### Notes

The actual cooling surface can differ because of the material, the structural shape, outside influences and the installation situation. Depending on the heat sink a heat conducting paste or heat conducting film might be necessary to keep the specified tp temperature.

### 3. Installation / wiring

#### 3.1 Electrical supply/choice of LED driver

LLE modules from Tridonic are not protected against overvoltages, overcurrents, overloads or short-circuit currents. Safe and reliable operation can only be guaranteed in conjunction with a LED driver which complies with the relevant standards. The use of LED driver from Tridonic in combination with LLE modules guarantees the necessary protection for safe and reliable operation.

If a LED driver other than Tridonic is used, it must provide the following protection:

- Short-circuit protection
- Overload protection
- Overtemperature protection



LLE modules must be supplied by a constant current LED driver. Operation with a constant voltage LED driver will lead to an irreversible damage of the module.

Wrong polarity can damage the LLE.

The LLE module is designed for serial wiring.

With parallel wiring tolerance-related differences in output are possible (thermal stress of the module) and can cause differences in brightness.

If a wire breaks or a complete module fails then the current passing through the other module increases. This may reduce its life considerably.

The max. permissible output current of the LED driver for parallel wiring is 1,080 mA.

Parallel wiring is only permitted with 280 mm or 560 mm modules.

LLE can be operated either from SELV LED drivers or from LED drivers with LV output voltage.



LLE are basic insulated up to 400 V (if mounted with M3 screws with head diameter 7 mm in combination with plastic washers) against ground and can be mounted directly on earthed metal parts of the luminaire. If the max. output voltage of the LED driver (also against earth) is above 400 V, an additional insulation between LED module and heat sink is required (for example by insulated thermal pads) or by a suitable luminaire construction.

At voltages > 60 V an additional protection against direct touch (test finger) to the light emitting side of the module has to be guaranteed.

This is typically achieved by means of a non removable light distributor over the module.

#### 3.2 Wiring

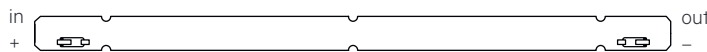

#### Wiring examples for serial wiring

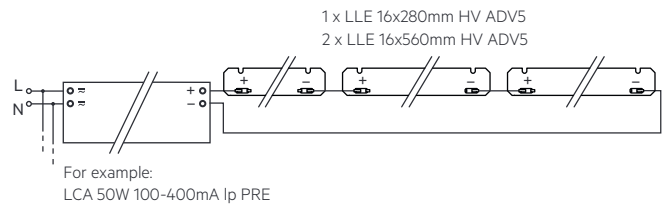
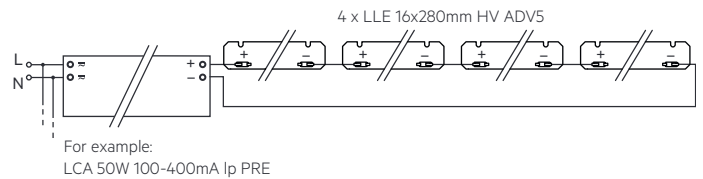

#### Wiring examples for parallel wiring

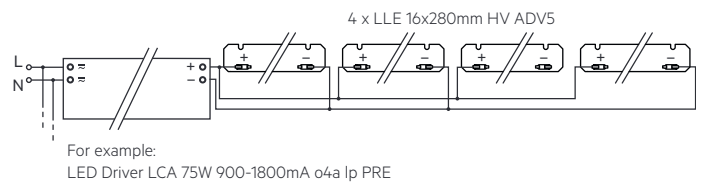

#### 3.3 Wiring type and cross section

For wiring use solid wire from 0.14 to 0.5 mm<sup>2</sup>.

No reconnection with smaller diameters possible if used with >0.34 mm<sup>2</sup>.

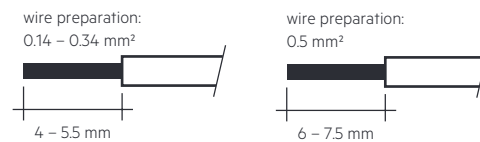

To remove the wires use a suitabel tool (Wago 206-859) or through twist and pull.



#### 3.4 Mounting instruction



None of the components of the LLE (substrate, LED, electronic components etc.) may be exposed to tensile or compressive stresses.

Max. torque for fixing: 0.5 Nm.

The LED modules are mounted onto a heat sink with min. 6 M3 screws with plastic washers per module or ACL BRIDGE LLE16 PUSH-FIX.

The LLE 16x70mm module is delivered as a board of 280mm (4 pcs.) and must be separated.

Only touch the module at the edge to separate the modules (see marking below).



Chemical substance may harm the LED module. Chemical reactions could lead to colour shift, reduced luminous flux or a total failure of the module caused by corrosion of electrical connections.

Materials which are used in LED applications (e.g. sealings, adhesives) must not produce dissolver gas. They must not be condensation curing based, acetate curing based or contain sulfur, chlorine or phthalate.

Avoid corrosive atmosphere during usage and storage.

#### 3.5 EOS/ESD safety guidelines



The device / module contains components that are sensitive to electrostatic discharge and may only be installed in the factory and on site if appropriate EOS/ESD protection measures have been taken. No special measures need be taken for devices/modules with enclosed casings (contact with the pc board not possible), just normal installation practice. Please note the requirements set out in the document EOS / ESD guidelines (Guideline\_EOS\_ESD.pdf) at: <http://www.tridonic.com/esd-protection>

## 4. Lifetime

### 4.1 Lifetime, lumen maintenance and failure rate

The light output of an LED module decreases over the lifetime, this is characterized with the L value.

L70 means that the LED module will give 70 % of its initial luminous flux.

This value is always related to the number of operation hours and therefore defines the lifetime of an LED module.

As the L value is a statistical value and the lumen maintenance may vary over the delivered LED modules.

The B value defines the amount of modules which are below the specific L value, e.g. L70B10 means 10 % of the LED modules are below 70 % of the initial luminous flux, respectively 90 % will be above 70 % of the initial value.

In addition the percentage of failed modules (fatal failure) is characterized by the C value.

The F value is the combination of the B and C value. That means for F degradation and complete failures are considered, e.g. L70F10 means 10 % of the LED modules may fail or be below 70 % of the initial luminous flux.

### 4.2 Lumen maintenance for LLE 16mm HV ADV5

Forward current	tp tempera- ture	tp						
		L90 / F10	L90 / F50	L80 / F10	L80 / F50	L70 / F10	L70 / F50	
150 mA	40 °C	43,000 h	59,000 h	>72,000 h	>72,000 h	>72,000 h	>72,000 h	
	45 °C	42,000 h	57,000 h	>72,000 h	>72,000 h	>72,000 h	>72,000 h	
	50 °C	41,000 h	55,000 h	>72,000 h	>72,000 h	>72,000 h	>72,000 h	
	55 °C	40,000 h	54,000 h	>72,000 h	>72,000 h	>72,000 h	>72,000 h	
	60 °C	39,000 h	52,000 h	>72,000 h	>72,000 h	>72,000 h	>72,000 h	
	65 °C	38,000 h	50,000 h	>72,000 h	>72,000 h	>72,000 h	>72,000 h	
	70 °C	38,000 h	49,000 h	>72,000 h	>72,000 h	>72,000 h	>72,000 h	
	75 °C	37,000 h	47,000 h	>72,000 h	>72,000 h	>72,000 h	>72,000 h	
	80 °C	36,000 h	46,000 h	>72,000 h	>72,000 h	>72,000 h	>72,000 h	
	85 °C	35,000 h	45,000 h	>72,000 h	>72,000 h	>72,000 h	>72,000 h	
	200 mA	40 °C	43,000 h	58,000 h	>72,000 h	>72,000 h	>72,000 h	>72,000 h
		45 °C	42,000 h	57,000 h	>72,000 h	>72,000 h	>72,000 h	>72,000 h
50 °C		41,000 h	55,000 h	>72,000 h	>72,000 h	>72,000 h	>72,000 h	
55 °C		40,000 h	53,000 h	>72,000 h	>72,000 h	>72,000 h	>72,000 h	
60 °C		39,000 h	51,000 h	>72,000 h	>72,000 h	>72,000 h	>72,000 h	
65 °C		38,000 h	50,000 h	>72,000 h	>72,000 h	>72,000 h	>72,000 h	
70 °C		37,000 h	48,000 h	>72,000 h	>72,000 h	>72,000 h	>72,000 h	
75 °C		36,000 h	47,000 h	>72,000 h	>72,000 h	>72,000 h	>72,000 h	
80 °C		36,000 h	45,000 h	>72,000 h	>72,000 h	>72,000 h	>72,000 h	
85 °C		35,000 h	44,000 h	>72,000 h	>72,000 h	>72,000 h	>72,000 h	
300 mA		40 °C	42,000 h	58,000 h	>72,000 h	>72,000 h	>72,000 h	>72,000 h
		45 °C	41,000 h	56,000 h	>72,000 h	>72,000 h	>72,000 h	>72,000 h
	50 °C	40,000 h	54,000 h	>72,000 h	>72,000 h	>72,000 h	>72,000 h	
	55 °C	40,000 h	52,000 h	>72,000 h	>72,000 h	>72,000 h	>72,000 h	
	60 °C	39,000 h	51,000 h	>72,000 h	>72,000 h	>72,000 h	>72,000 h	
	65 °C	38,000 h	49,000 h	>72,000 h	>72,000 h	>72,000 h	>72,000 h	
	70 °C	37,000 h	48,000 h	>72,000 h	>72,000 h	>72,000 h	>72,000 h	
	75 °C	36,000 h	46,000 h	>72,000 h	>72,000 h	>72,000 h	>72,000 h	
	80 °C	35,000 h	45,000 h	>72,000 h	>72,000 h	>72,000 h	>72,000 h	
	85 °C	34,000 h	44,000 h	70,000 h	>72,000 h	>72,000 h	>72,000 h	

Forward current	tp tempera- ture	tp						
		L90 / F10	L90 / F50	L80 / F10	L80 / F50	L70 / F10	L70 / F50	
375 mA	40 °C	42,000 h	57,000 h	>72,000 h	>72,000 h	>72,000 h	>72,000 h	
	45 °C	41,000 h	55,000 h	>72,000 h	>72,000 h	>72,000 h	>72,000 h	
	50 °C	40,000 h	54,000 h	>72,000 h	>72,000 h	>72,000 h	>72,000 h	
	55 °C	39,000 h	52,000 h	>72,000 h	>72,000 h	>72,000 h	>72,000 h	
	60 °C	38,000 h	50,000 h	>72,000 h	>72,000 h	>72,000 h	>72,000 h	
	65 °C	37,000 h	49,000 h	>72,000 h	>72,000 h	>72,000 h	>72,000 h	
	70 °C	37,000 h	47,000 h	>72,000 h	>72,000 h	>72,000 h	>72,000 h	
	75 °C	36,000 h	46,000 h	>72,000 h	>72,000 h	>72,000 h	>72,000 h	
	80 °C	35,000 h	44,000 h	71,000 h	>72,000 h	>72,000 h	>72,000 h	
	85 °C	34,000 h	43,000 h	69,000 h	>72,000 h	>72,000 h	>72,000 h	
	450 mA	40 °C	42,000 h	56,000 h	>72,000 h	>72,000 h	>72,000 h	>72,000 h
		45 °C	41,000 h	55,000 h	>72,000 h	>72,000 h	>72,000 h	>72,000 h
50 °C		40,000 h	53,000 h	>72,000 h	>72,000 h	>72,000 h	>72,000 h	
55 °C		39,000 h	51,000 h	>72,000 h	>72,000 h	>72,000 h	>72,000 h	
60 °C		38,000 h	50,000 h	>72,000 h	>72,000 h	>72,000 h	>72,000 h	
65 °C		37,000 h	48,000 h	>72,000 h	>72,000 h	>72,000 h	>72,000 h	
70 °C		36,000 h	47,000 h	>72,000 h	>72,000 h	>72,000 h	>72,000 h	
75 °C		35,000 h	45,000 h	>72,000 h	>72,000 h	>72,000 h	>72,000 h	
80 °C		35,000 h	44,000 h	70,000 h	>72,000 h	>72,000 h	>72,000 h	
85 °C		34,000 h	43,000 h	69,000 h	>72,000 h	>72,000 h	>72,000 h	
500 mA		40 °C	41,000 h	56,000 h	>72,000 h	>72,000 h	>72,000 h	>72,000 h
		45 °C	40,000 h	54,000 h	>72,000 h	>72,000 h	>72,000 h	>72,000 h
	50 °C	39,000 h	52,000 h	>72,000 h	>72,000 h	>72,000 h	>72,000 h	
	55 °C	38,000 h	51,000 h	>72,000 h	>72,000 h	>72,000 h	>72,000 h	
	60 °C	38,000 h	49,000 h	>72,000 h	>72,000 h	>72,000 h	>72,000 h	
	65 °C	37,000 h	48,000 h	>72,000 h	>72,000 h	>72,000 h	>72,000 h	
	70 °C	36,000 h	46,000 h	>72,000 h	>72,000 h	>72,000 h	>72,000 h	
	75 °C	35,000 h	45,000 h	71,000 h	>72,000 h	>72,000 h	>72,000 h	
	80 °C	34,000 h	43,000 h	70,000 h	>72,000 h	>72,000 h	>72,000 h	
	85 °C	34,000 h	42,000 h	68,000 h	>72,000 h	>72,000 h	>72,000 h	

### 4.3 Switching capability

100,000 cycles

Tridonic test according to IEC 62717 Cl 10.3.3

30 s on / 30 s off at I<sub>max</sub>

## 5. Electrical values

### 5.1 Declaration of electrical parameters

$I_{rated}$  ... Nominal operating current the module is designed for.

$I_{max}$  ... Max. permissible continuous operating current incl. The tolerances of the LED driver.

Max. permissible LF current ripple ... Max. output current of the LED driver incl. Tolerances and LF current ripple must not exceed this value.

Max. permissible peak current ... The max. output peak current of the LED driver must not exceed this value.

### 5.2 Typ. forward voltage vs. forward current

LLE 16x70mm 325lm 8xx HV ADV5

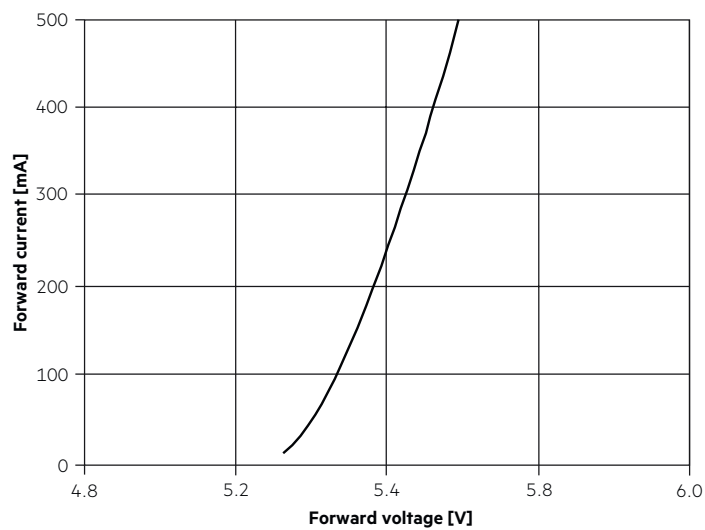

LLE 16x140mm 650lm 8xx HV ADV5

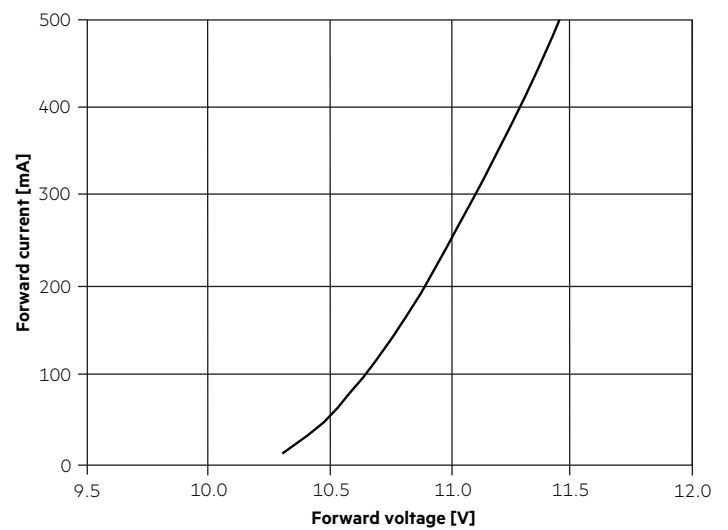

LLE 16x280mm 1250lm 8xx HV ADV5

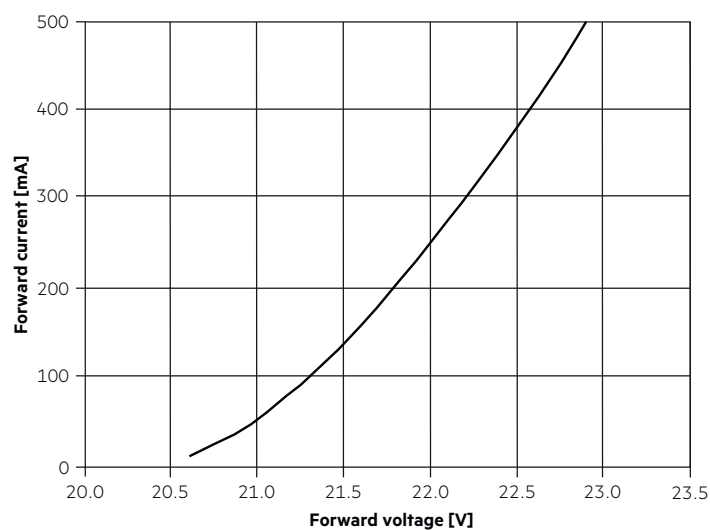

LLE 16x560mm 2400lm 8xx HV ADV5

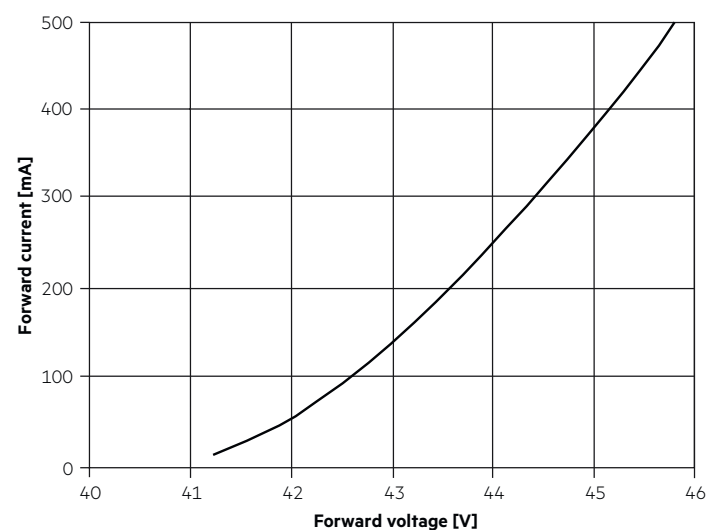

The diagrams are based on statistic values.

The real values can be different.

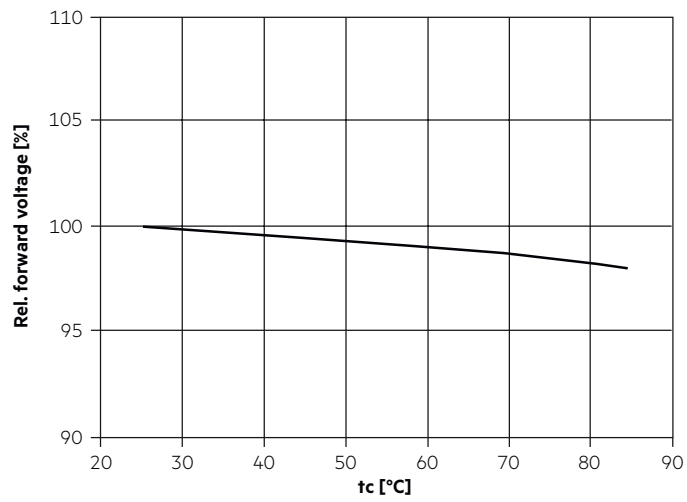
5.3 Forward voltage vs.  $t_c$  temperature

The diagrams are based on statistic values.  
The real values can be different.

## 6. Photometric characteristics

### 6.1 Coordinates and tolerances according to CIE 1931

The specified colour coordinates are integral measured by current impulse of 195 mA and a duration of 100 ms.  
 The ambient temperature of the measurement is  $t_a = 25^\circ\text{C}$ .  
 The measurement tolerance of the colour coordinates are  $\pm 0.01$ .

#### 2,700 K

	x0	y0
Centre	0.4578	0.4101

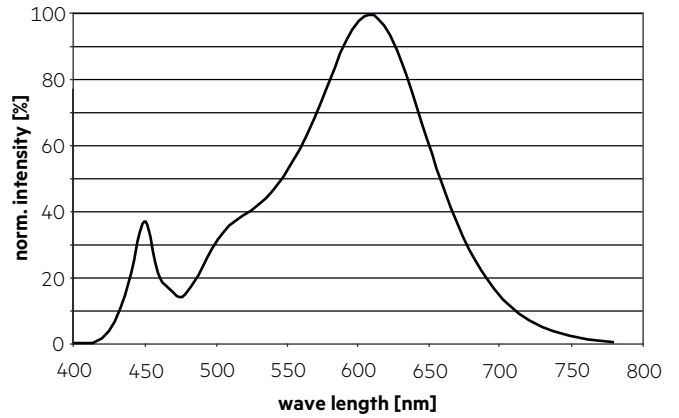
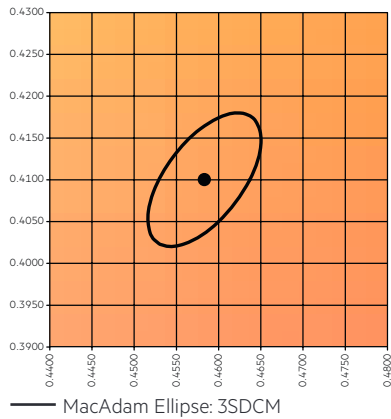

#### 3,000 K

	x0	y0
Centre	0.4338	0.4030

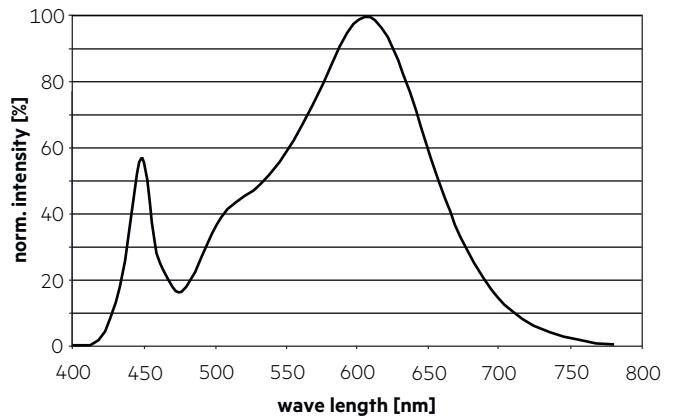
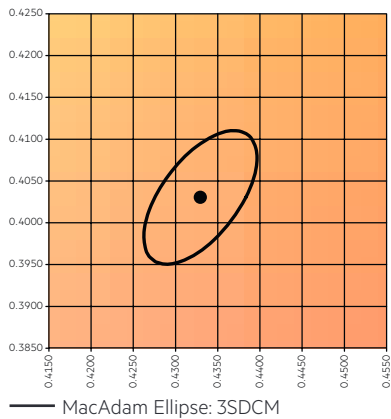

#### 3,500 K

	x0	y0
Centre	0.4069	0.3905

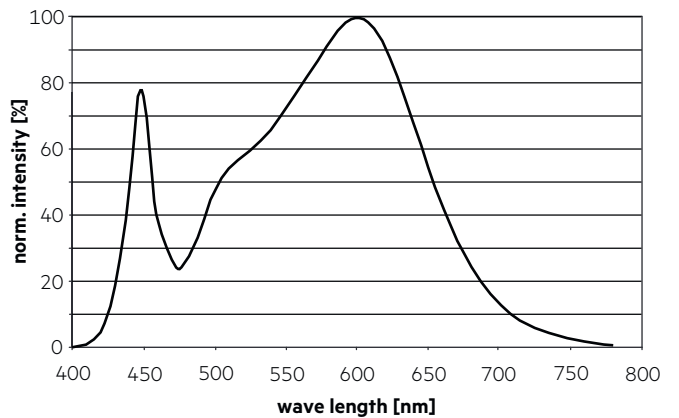
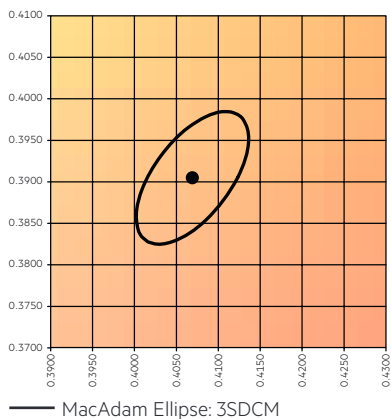

4,000 K

	x0	y0
Center	0.3818	0.3797

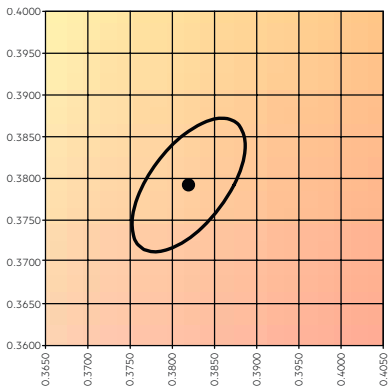

— MacAdam Ellipse: 3SDCM

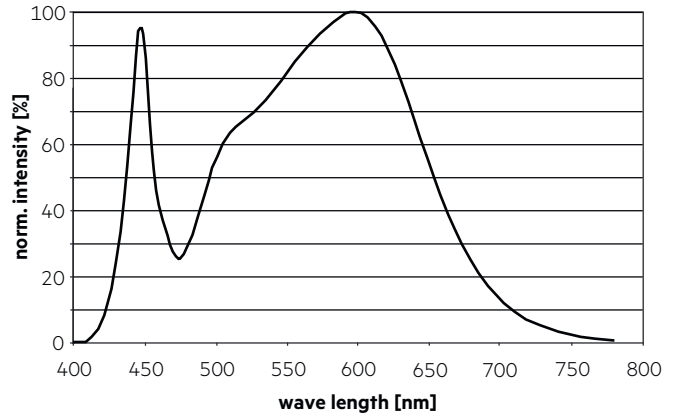

5,000 K

	x0	y0
Center	0.3447	0.3553

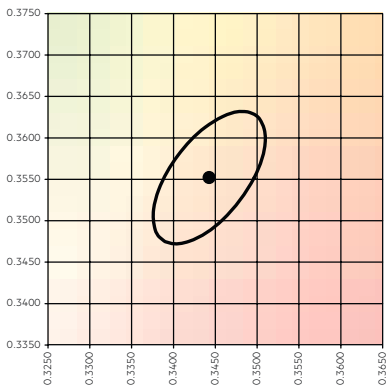

— MacAdam Ellipse: 3SDCM

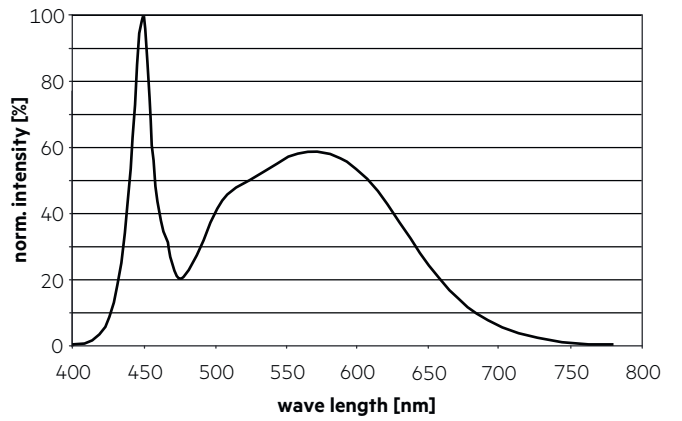

6,500 K

	x0	y0
Center	0.3123	0.3282

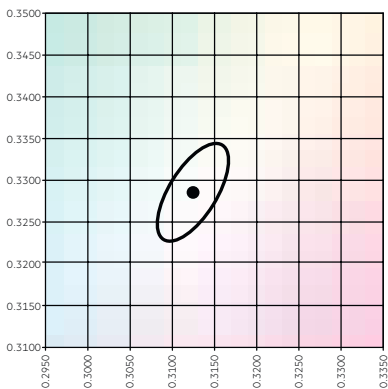

— MacAdam Ellipse: 3SDCM

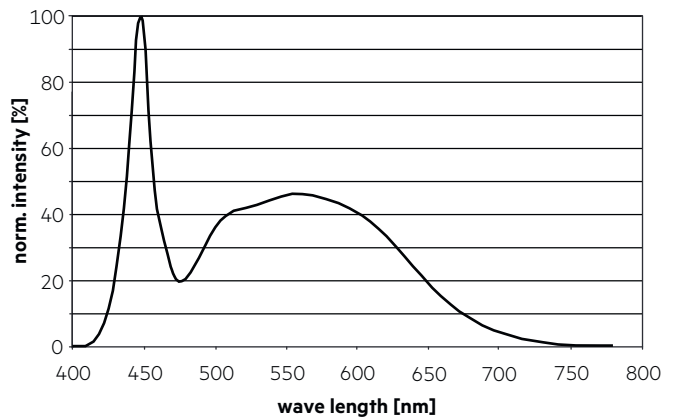

## 6.2 Light distribution

The optical design of the LLE product line ensures optimum homogeneity for the light distribution.

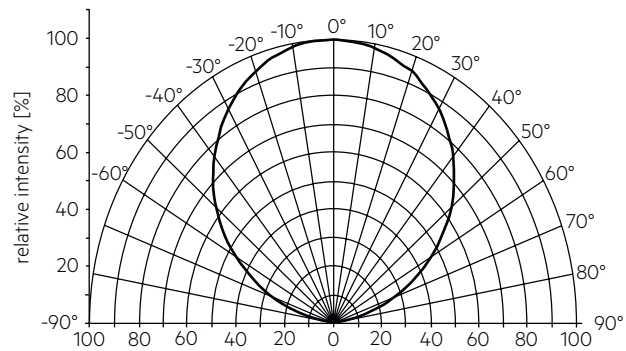

The colour temperature is measured integral over the complete module. The single LED light points can have deviations in the colour coordinates within MacAdam 5.

To ensure an ideal mixture of colours and a homogeneous light distribution a suitable optic (e. g. PMMA diffuser) and a sufficient spacing between module and optic (typ. 4 cm) should be used.

## 6.3 Relative luminous flux vs. tc temperature

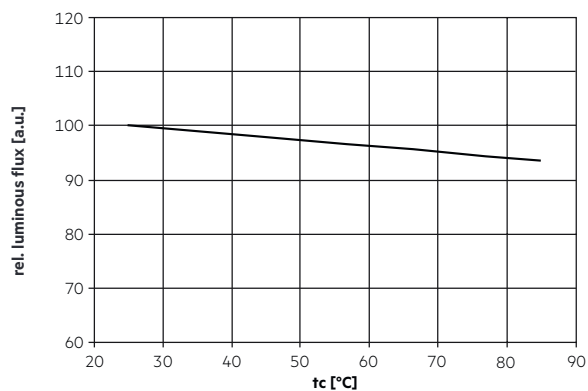

## 6.4 Relative luminous flux vs. operating current

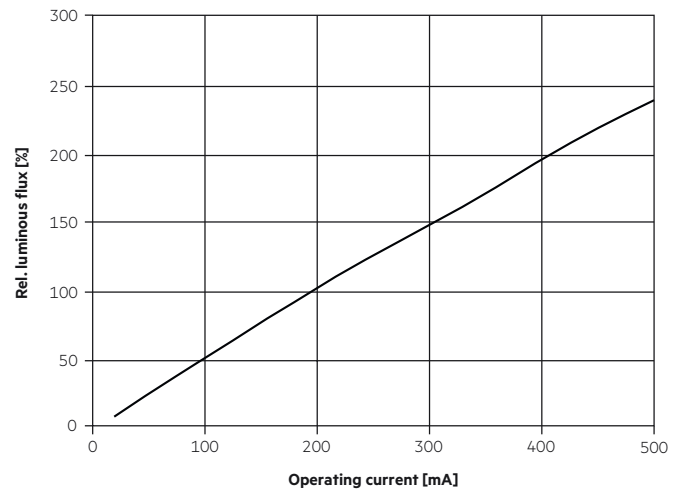

The diagrams are based on statistic values.  
The real values can be different.

## 7. Miscellaneous

### 7.1 Additional information

Additional technical information at [www.tridonic.com](http://www.tridonic.com) → Technical Data

Guarantee conditions at [www.tridonic.com](http://www.tridonic.com) → Services

Lifetime declarations are informative and represent no warranty claim.