

Module CLE ADV4

Modules CLE advanced



CLE 160mm 3000lm ADV4



CLE 190mm 2500lm ADV4 EM

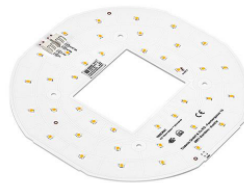

CLE 190mm 2500lm ADV4 EM SO

Product description

- _ Ideal for ceiling-mounted and wallmounted luminaires
- _ SO version is compatible with SWITCH Sensor HF 5BP
- _ Integrated separate emergency LEDs with CLE 190/220/315 controlled by EM powerLED
- _ Push terminals for quick and simple wiring
- _ HE ... High Efficiency, NM ... Nominal Mode, HO ... High Output
- _ Long lifetime up to 72,000 hours
- _ 5 years guarantee (conditions at

<https://www.tridonic.com/manufacture-guarantee-conditions>)

Optical properties

- _ Colour temperatures 3,000 and 4,000 K
- _ Useful luminous flux 3,200 lm at Irated and tp = 25 °C
- _ Efficacy of the LED module 199 lm/W at Irated and tp = 25 °C
- _ High colour rendering index CRI > 80
- _ Small colour tolerance (MacAdam 3) ①
- _ Small luminous flux tolerances

Mechanical properties

- _ Module dimension $\varnothing 160$ mm, $\varnothing 190$ mm, $\varnothing 220$ mm and $\varnothing 315$ mm
- _ Simple installation (e.g. screws)

System solution

- _ LED system solution consisting of the LED module, the LED driver with integrated emergency function and SWITCH sensor

① Integral measurement over the complete module.

Website

<http://www.tridonic.com/28002947>



Spotlights



Downlights



Linear



Area



Floor | Wall



Free-standing



Street



Decorative



High bay

Module CLE ADV4

Modules CLE advanced

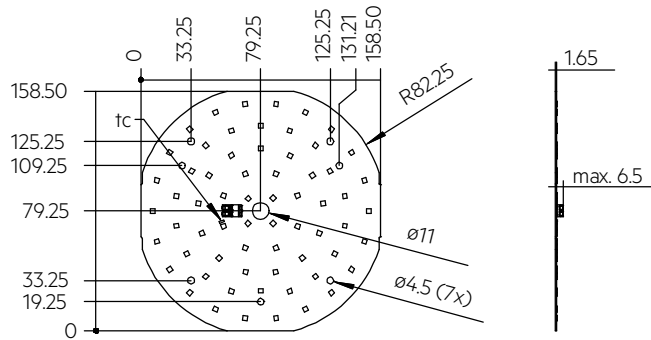

CLE 160mm 3000lm ADV4

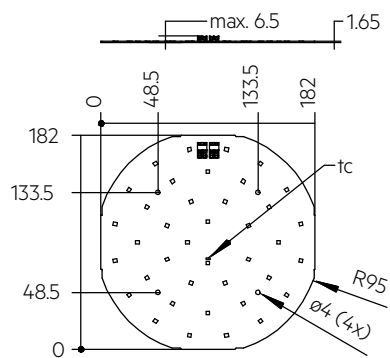

CLE 190mm 2500lm ADV4 EM

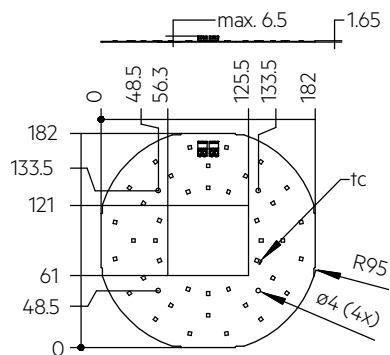

CLE 190mm 2500lm ADV4 EM SO

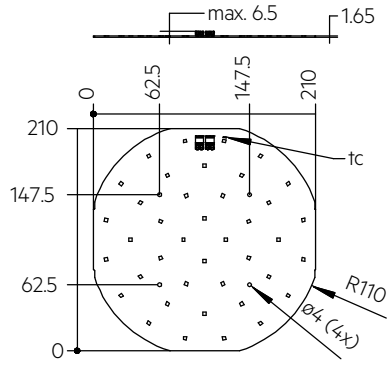

CLE 220mm 2500lm ADV4 EM

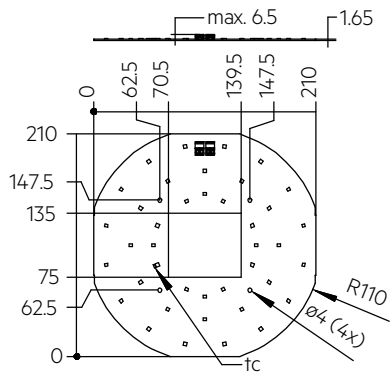

CLE 220mm 2500lm ADV4 EM SO

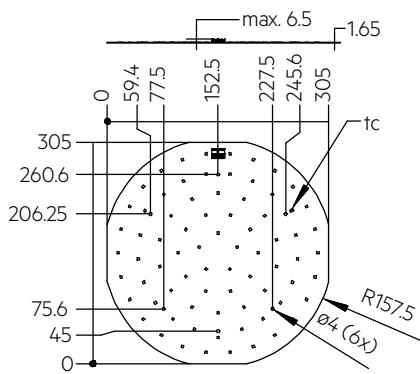

CLE 315mm 4000lm ADV4 EM

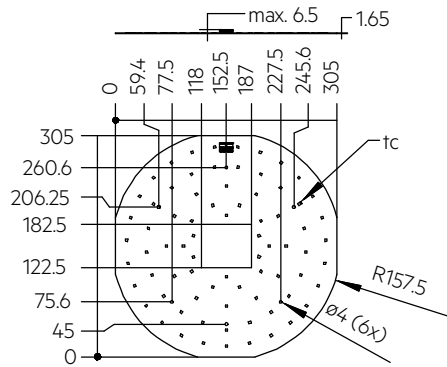

CLE 315mm 4000lm ADV4 EM SO

Ordering data

Type	Article number	Colour temperature	Packaging, carton	Weight per pc.
CLE 160mm 3000lm 830 ADV4	28002947	3,000 K	20 pc(s).	0.059 kg
CLE 160mm 3000lm 840 ADV4	28002948	4,000 K	20 pc(s).	0.059 kg
CLE 190mm 2500lm 830 ADV4 EM	28002949	3,000 K	20 pc(s).	0.075 kg
CLE 190mm 2500lm 840 ADV4 EM	28002950	4,000 K	20 pc(s).	0.075 kg
CLE 190mm 2500lm 830 ADV4 EM SO	28002951	3,000 K	20 pc(s).	0.064 kg
CLE 190mm 2500lm 840 ADV4 EM SO	28002952	4,000 K	20 pc(s).	0.064 kg
CLE 220mm 2500lm 830 ADV4 EM	28002953	3,000 K	50 pc(s).	0.099 kg
CLE 220mm 2500lm 840 ADV4 EM	28002954	4,000 K	50 pc(s).	0.099 kg
CLE 220mm 2500lm 830 ADV4 EM SO	28002955	3,000 K	50 pc(s).	0.088 kg
CLE 220mm 2500lm 840 ADV4 EM SO	28002956	4,000 K	50 pc(s).	0.088 kg
CLE 315mm 4000lm 830 ADV4 EM	28002957	3,000 K	10 pc(s).	0.208 kg
CLE 315mm 4000lm 840 ADV4 EM	28002958	4,000 K	10 pc(s).	0.208 kg
CLE 315mm 4000lm 830 ADV4 EM SO	28002959	3,000 K	10 pc(s).	0.199 kg
CLE 315mm 4000lm 840 ADV4 EM SO	28002960	4,000 K	10 pc(s).	0.199 kg

Technical data

Beam characteristic	120°
Ambient temperature t_a	-25 ... +45 °C
t_p rated	65 °C
t_c	85 °C
I _{rated} for CLE 160mm	350 mA
I _{rated} for CLE 190/220mm	350 mA
I _{rated} for CLE 315mm	600 mA
I _{max} for CLE 160mm	850 mA
I _{max} for CLE 190/220mm	700 mA
I _{max} for CLE 315mm	1,200 mA
Max. permissible LF current ripple for CLE 160mm	1,000 mA
Max. permissible LF current ripple for CLE 190/220mm	800 mA
Max. permissible LF current ripple for CLE 315mm	1,400 mA
Max. permissible peak current for CLE 160mm	1,500 mA / max. 10 ms
Max. permissible peak current for CLE 190/220mm	1,200 mA / max. 10 ms
Max. permissible peak current for CLE 315mm	2,100 mA / max. 10 ms
Max. working voltage for insulation SELV [®]	< 60 V
Insulation test voltage	0.5 kV
Colour tolerance	3 SDCM
ESD classification	Severity level 4
Risk group (IEC 62471)	RG1
Type of protection	IP00
Lumen maintenance L70B50	72,000 h
Guarantee (conditions at www.tridonic.com)	5 Year(s)

Approval marks**Standards**

IEC 62031, IEC 62471, IEC 62778, IEC 61547

Specific technical data

Type	Article number	Photometric code	Useful luminous flux at tp = 25 °C ^③	Expected luminous flux at tp rated ^④	Typ. forward current	Min. forward voltage at tp rated	Max. forward voltage at tp = 25 °C	Power consumption ^⑤	Efficacy of the module at tp = 25 °C	Expected efficacy of the module at tp rated	Colour rendering index CRI
CLE 160mm – Operating mode NM											
CLE 160mm 3000lm 830 ADV4	28002947	830/359	2,360 lm	2,250 lm	350 mA	33.5 V	36.5 V	12.4 W	190 lm/W	183 lm/W	>80
CLE 160mm 3000lm 840 ADV4	28002948	840/359	2,470 lm	2,360 lm	350 mA	33.5 V	36.5 V	12.4 W	199 lm/W	192 lm/W	>80
CLE 160mm – Operating mode HO											
CLE 160mm 3000lm 830 ADV4	28002947	830/359	-	3,100 lm	500 mA	34.1 V	37.1 V	-	-	174 lm/W	>80
CLE 160mm 3000lm 840 ADV4	28002948	840/359	-	3,240 lm	500 mA	34.1 V	37.1 V	-	-	182 lm/W	>80
CLE 190/220mm – Operating mode NM											
CLE 190mm 2500lm 830 ADV4 EM	28002949	830/359	1,600 lm	1,530 lm	350 mA	23.4 V	25.5 V	8.7 W	184 lm/W	178 lm/W	>80
CLE 190mm 2500lm 840 ADV4 EM	28002950	840/359	1,680 lm	1,600 lm	350 mA	23.4 V	25.5 V	8.7 W	193 lm/W	186 lm/W	>80
CLE 190mm 2500lm 830 ADV4 EM SO	28002951	830/359	1,600 lm	1,530 lm	350 mA	23.4 V	25.5 V	8.7 W	184 lm/W	178 lm/W	>80
CLE 190mm 2500lm 840 ADV4 EM SO	28002952	840/359	1,680 lm	1,600 lm	350 mA	23.4 V	25.5 V	8.7 W	193 lm/W	186 lm/W	>80
CLE 220mm 2500lm 830 ADV4 EM	28002953	830/359	1,600 lm	1,530 lm	350 mA	23.4 V	25.5 V	8.7 W	184 lm/W	178 lm/W	>80
CLE 220mm 2500lm 840 ADV4 EM	28002954	840/359	1,680 lm	1,600 lm	350 mA	23.4 V	25.5 V	8.7 W	193 lm/W	186 lm/W	>80
CLE 220mm 2500lm 830 ADV4 EM SO	28002955	830/359	1,600 lm	1,530 lm	350 mA	23.4 V	25.5 V	8.7 W	184 lm/W	178 lm/W	>80
CLE 220mm 2500lm 840 ADV4 EM SO	28002956	840/359	1,680 lm	1,600 lm	350 mA	23.4 V	25.5 V	8.7 W	193 lm/W	186 lm/W	>80
CLE 190/220mm – Operating mode HO at 500 mA											
CLE 190mm 2500lm 830 ADV4 EM	28002949	830/359	-	2,120 lm	500 mA	23.9 V	26.0 V	-	-	170 lm/W	>80
CLE 190mm 2500lm 840 ADV4 EM	28002950	840/359	-	2,220 lm	500 mA	23.9 V	26.0 V	-	-	177 lm/W	>80
CLE 190mm 2500lm 830 ADV4 EM SO	28002951	830/359	-	2,120 lm	500 mA	23.9 V	26.0 V	-	-	170 lm/W	>80
CLE 190mm 2500lm 840 ADV4 EM SO	28002952	840/359	-	2,220 lm	500 mA	23.9 V	26.0 V	-	-	177 lm/W	>80
CLE 220mm 2500lm 830 ADV4 EM	28002953	830/359	-	2,120 lm	500 mA	23.9 V	26.0 V	-	-	170 lm/W	>80
CLE 220mm 2500lm 840 ADV4 EM	28002954	840/359	-	2,220 lm	500 mA	23.9 V	26.0 V	-	-	177 lm/W	>80
CLE 220mm 2500lm 830 ADV4 EM SO	28002955	830/359	-	2,120 lm	500 mA	23.9 V	26.0 V	-	-	170 lm/W	>80
CLE 220mm 2500lm 840 ADV4 EM SO	28002956	840/359	-	2,220 lm	500 mA	23.9 V	26.0 V	-	-	177 lm/W	>80
CLE 190/220mm – Operating mode HO at 600 mA											
CLE 190mm 2500lm 830 ADV4 EM	28002949	830/359	-	2,540 lm	600 mA	24.2 V	26.3 V	-	-	167 lm/W	>80
CLE 190mm 2500lm 840 ADV4 EM	28002950	840/359	-	2,660 lm	600 mA	24.2 V	26.3 V	-	-	174 lm/W	>80
CLE 190mm 2500lm 830 ADV4 EM SO	28002951	830/359	-	2,540 lm	600 mA	24.2 V	26.3 V	-	-	167 lm/W	>80
CLE 190mm 2500lm 840 ADV4 EM SO	28002952	840/359	-	2,660 lm	600 mA	24.2 V	26.3 V	-	-	174 lm/W	>80
CLE 220mm 2500lm 830 ADV4 EM	28002953	830/359	-	2,540 lm	600 mA	24.2 V	26.3 V	-	-	167 lm/W	>80
CLE 220mm 2500lm 840 ADV4 EM	28002954	840/359	-	2,660 lm	600 mA	24.2 V	26.3 V	-	-	174 lm/W	>80
CLE 220mm 2500lm 830 ADV4 EM SO	28002955	830/359	-	2,540 lm	600 mA	24.2 V	26.3 V	-	-	167 lm/W	>80
CLE 220mm 2500lm 840 ADV4 EM SO	28002956	840/359	-	2,660 lm	600 mA	24.2 V	26.3 V	-	-	174 lm/W	>80
CLE 190/220mm – Emergency operation at 320 mA (EM powerLED NM 1 W BASIC, EM powerLED 15 W BASIC CLE NiCd)											
CLE 190mm 2500lm 830 ADV4 EM	28002949	830/359	-	320 mA	-	-	-	-	-	-	>80
CLE 190mm 2500lm 840 ADV4 EM	28002950	840/359	-	320 mA	-	-	-	-	-	-	>80
CLE 190mm 2500lm 830 ADV4 EM SO	28002951	830/359	-	320 mA	-	-	-	-	-	-	>80
CLE 190mm 2500lm 840 ADV4 EM SO	28002952	840/359	-	320 mA	-	-	-	-	-	-	>80
CLE 220mm 2500lm 830 ADV4 EM	28002953	830/359	-	320 mA	-	-	-	-	-	-	>80
CLE 220mm 2500lm 840 ADV4 EM	28002954	840/359	-	320 mA	-	-	-	-	-	-	>80
CLE 220mm 2500lm 830 ADV4 EM SO	28002955	830/359	-	320 mA	-	-	-	-	-	-	>80
CLE 220mm 2500lm 840 ADV4 EM SO	28002956	840/359	-	320 mA	-	-	-	-	-	-	>80
CLE 190/220mm – Emergency operation at 350 mA (EM powerLED 1 W)											
CLE 190mm 2500lm 830 ADV4 EM	28002949	830/359	178 lm	171 lm	350 mA	-	-	-	-	-	>80
CLE 190mm 2500lm 840 ADV4 EM	28002950	840/359	187 lm	179 lm	350 mA	-	-	-	-	-	>80
CLE 190mm 2500lm 830 ADV4 EM SO	28002951	830/359	178 lm	171 lm	350 mA	-	-	-	-	-	>80
CLE 190mm 2500lm 840 ADV4 EM SO	28002952	840/359	187 lm	179 lm	350 mA	-	-	-	-	-	>80
CLE 220mm 2500lm 830 ADV4 EM	28002953	830/359	178 lm	171 lm	350 mA	-	-	-	-	-	>80
CLE 220mm 2500lm 840 ADV4 EM	28002954	830/359	178 lm	171 lm	350 mA	-	-	-	-	-	>80
CLE 220mm 2500lm 830 ADV4 EM SO	28002955	830/359	178 lm	171 lm	350 mA	-	-	-	-	-	>80
CLE 220mm 2500lm 840 ADV4 EM SO	28002956	840/359	187 lm	179 lm	350 mA	-	-	-	-	-	>80
CLE 190/220mm – Emergency operation at 400 mA (EM powerLED 15 W BASIC CLE NiMH)											
CLE 190mm 2500lm 830 ADV4 EM	28002949	830/359	-	400 mA	-	-	-	-	-	-	>80
CLE 190mm 2500lm 840 ADV4 EM	28002950	840/359	-	400 mA	-	-	-	-	-	-	>80
CLE 190mm 2500lm 830 ADV4 EM SO	28002951	830/359	-	400 mA	-	-	-	-	-	-	>80
CLE 190mm 2500lm 840 ADV4 EM SO	28002952	840/359	-	400 mA	-	-	-	-	-	-	>80
CLE 220mm 2500lm 830 ADV4 EM	28002953	830/359	-	400 mA	-	-	-	-	-	-	>80
CLE 220mm 2500lm 840 ADV4 EM	28002954	840/359	-	400 mA	-	-	-	-	-	-	>80
CLE 220mm 2500lm 830 ADV4 EM SO	28002955	830/359	-	400 mA	-	-	-	-	-	-	>80
CLE 220mm 2500lm 840 ADV4 EM SO	28002956	840/359	-	400 mA	-	-	-	-	-	-	>80
CLE 190/220mm – Emergency operation at 600 mA (EM powerLED 2 W)											
CLE 190mm 2500lm 830 ADV4 EM	28002949	830/359	295 lm	282 lm	600 mA	-	-	-	-	-	>80
CLE 190mm 2500lm 840 ADV4 EM	28002950	840/359	309 lm	296 lm	600 mA	-	-	-	-	-	>80
CLE 190mm 2500lm 830 ADV4 EM SO	28002951	830/359	295 lm	282 lm	600 mA	-	-	-	-	-	>80
CLE 190mm 2500lm 840 ADV4 EM SO	28002952	840/359	309 lm	296 lm	600 mA	-	-	-	-	-	>80
CLE 220mm 2500lm 830 ADV4 EM	28002953	830/359	295 lm	282 lm	600 mA	-	-	-	-	-	>80
CLE 220mm 2500lm 840 ADV4 EM	28002954	840/359	309 lm	296 lm	600 mA	-	-	-	-	-	>80

Type	Article number	Photometric code	Useful luminous flux at tp = 25 °C ^③	Expected luminous flux at tp rated ^④	Typ. forward current	Min. forward voltage at tp rated	Max. forward voltage at tp = 25 °C	Power consumption Pon at tp = 25 °C ^⑤	Efficacy of the module at tp = 25 °C	Expected efficacy of the module at tp rated	Colour rendering index CRI
CLE 220mm 2500lm 830 ADV4 EM SO	28002955	830/359	295 lm	282 lm	600 mA	-	-	-	-	-	>80
CLE 220mm 2500lm 840 ADV4 EM SO	28002956	840/359	309 lm	296 lm	600 mA	-	-	-	-	-	>80
CLE 315mm – Operating mode NM											
CLE 315mm 4000lm 830 ADV4 EM	28002957	830/359	3,060 lm	2,920 lm	600 mA	26.0 V	28.3 V	16.5 W	185 lm/W	179 lm/W	>80
CLE 315mm 4000lm 840 ADV4 EM	28002958	840/359	3,200 lm	3,065 lm	600 mA	26.0 V	28.3 V	16.5 W	194 lm/W	188 lm/W	>80
CLE 315mm 4000lm 830 ADV4 EM SO	28002959	830/359	3,060 lm	2,920 lm	600 mA	26.0 V	28.3 V	16.5 W	185 lm/W	179 lm/W	>80
CLE 315mm 4000lm 840 ADV4 EM SO	28002960	840/359	3,200 lm	3,065 lm	600 mA	26.0 V	28.3 V	16.5 W	194 lm/W	188 lm/W	>80
CLE 315mm – Operating mode HO											
CLE 315mm 4000lm 830 ADV4 EM	28002957	830/359	-	4,280 lm	900 mA	26.6 V	28.9 V	-	-	171 lm/W	>80
CLE 315mm 4000lm 840 ADV4 EM	28002958	840/359	-	4,480 lm	900 mA	26.6 V	28.9 V	-	-	179 lm/W	>80
CLE 315mm 4000lm 830 ADV4 EM SO	28002959	830/359	-	4,280 lm	900 mA	26.6 V	28.9 V	-	-	171 lm/W	>80
CLE 315mm 4000lm 840 ADV4 EM SO	28002960	840/359	-	4,480 lm	900 mA	26.6 V	28.9 V	-	-	179 lm/W	>80
CLE 315mm – Emergency operation at 600 mA (EM powerLED 2 W)											
CLE 315mm 4000lm 830 ADV4 EM	28002957	830/359	300 lm	280 lm	600 mA	-	-	-	-	-	>80
CLE 315mm 4000lm 840 ADV4 EM	28002958	840/359	313 lm	300 lm	600 mA	-	-	-	-	-	>80
CLE 315mm 4000lm 830 ADV4 EM SO	28002959	830/359	300 lm	280 lm	600 mA	-	-	-	-	-	>80
CLE 315mm 4000lm 840 ADV4 EM SO	28002960	840/359	313 lm	300 lm	600 mA	-	-	-	-	-	>80
CLE 315mm – Emergency operation at 1,000 mA (EM powerLED 4 W)											
CLE 315mm 4000lm 830 ADV4 EM	28002957	830/359	-	-	1,000 mA	-	-	-	-	-	>80
CLE 315mm 4000lm 840 ADV4 EM	28002958	840/359	-	-	1,000 mA	-	-	-	-	-	>80
CLE 315mm 4000lm 830 ADV4 EM SO	28002959	830/359	-	-	1,000 mA	-	-	-	-	-	>80
CLE 315mm 4000lm 840 ADV4 EM SO	28002960	840/359	-	-	1,000 mA	-	-	-	-	-	>80

② If mounted with M4 screws and plastic washers.

③ Tolerance of useful light flux - 0 % / + 15 %. Measurement uncertainty ± 10 %.

④ Tolerance of expected light flux - 0 % / + 15 %. Measurement uncertainty ± 10 %. Based on calculation.

⑤ Tolerance of power consumption Pon ± 10 %. Measurement uncertainty ± 5 %.

1. Standards

IEC 62031
IEC 62471
IEC 62778
IEC 61547

1.1 Photometric code

Key for photometric code, e. g. 830 / 359

1 st digit	2 nd + 3 rd digit	4 th digit	5 th digit	6 th digit	
Code CRI	Colour temperature in Kelvin x 100	MacAdam initial	MacAdam after 25% of the lifetime (max.6000h)	Luminous flux after 25% of the lifetime (max.6000h)	
7 70 – 79				Code	Luminous flux
8 80 – 89				7	≥ 70 %
9 ≥90				8	≥ 80 %
				9	≥ 90 %

1.2 Energy classification

Type	Colour temperature	Forward current	Energy classification	Energy consumption
CLE 160mm 3000lm				
CLE 160mm 3000lm 830 ADV4	3,000 K	350 mA	C	13 kWh / 1,000 h
CLE 160mm 3000lm 840 ADV4	4,000 K	350 mA	C	13 kWh / 1,000 h
CLE 190mm 2500lm				
CLE 190mm 2500lm 830 ADV4 EM	3,000 K	350 mA	C	9 kWh / 1,000 h
CLE 190mm 2500lm 840 ADV4 EM	4,000 K	350 mA	C	9 kWh / 1,000 h
CLE 190mm 2500lm 830 ADV4 EM SO	3,000 K	350 mA	C	9 kWh / 1,000 h
CLE 190mm 2500lm 840 ADV4 EM SO	4,000 K	350 mA	C	9 kWh / 1,000 h
CLE 220mm 2500lm				
CLE 220mm 2500lm 830 ADV4 EM	3,000 K	350 mA	C	9 kWh / 1,000 h
CLE 220mm 2500lm 840 ADV4 EM	4,000 K	350 mA	C	9 kWh / 1,000 h
CLE 220mm 2500lm 830 ADV4 EM SO	3,000 K	350 mA	C	9 kWh / 1,000 h
CLE 220mm 2500lm 840 ADV4 EM SO	4,000 K	350 mA	C	9 kWh / 1,000 h
CLE 315mm 4000lm				
CLE 315mm 4000lm 830 ADV4 EM	3,000 K	600 mA	C	17 kWh / 1,000 h
CLE 315mm 4000lm 840 ADV4 EM	4,000 K	600 mA	C	17 kWh / 1,000 h
CLE 315mm 4000lm 830 ADV4 EM SO	3,000 K	600 mA	C	17 kWh / 1,000 h
CLE 315mm 4000lm 840 ADV4 EM SO	4,000 K	600 mA	C	17 kWh / 1,000 h

Energy label and further information at www.tridonic.com in the certificates tab of the corresponding product page and at the EPREL data base <https://eprel.ec.europa.eu/>

2. Thermal details

2.1 tp point, ambient temperature and lifetime

The temperature at tp reference point is crucial for the light output and lifetime of a LED product.

For CLE a tp temperature of 65°C has to be complied in order to achieve an optimum between light output and lifetime.

Compliance with the maximum permissible reference temperature at the tc point must be checked under operating conditions in a thermally stable state. The maximum value must be determined under worst-case conditions for the relevant application.

The tc and tp temperature of LED modules from Tridonic are measured at the same reference point.

2.2 Storage and humidity

Storage temperature	-40...+85 °C
---------------------	--------------

Operation only in non condensing environment.

Humidity during processing of the module should be between 30 to 70 %.

2.3 Thermal design and heat sink

The rated life of LED products depends to a large extent on the temperature. If the permissible temperature limits are exceeded, the life of the CLE will be greatly reduced or the CLE may be destroyed.

2.4 Heat sink values

CLE 160mm 3000lm

ta	tp	Forward current	R _{th, hs-a}	Cooling area
25°C	65°C	350 mA		self-cooling
35°C	65°C	350 mA		self-cooling
40°C	65°C	350 mA		self-cooling
45°C	65°C	350 mA		self-cooling
25°C	65°C	500 mA		self-cooling
35°C	65°C	500 mA		self-cooling
40°C	65°C	500 mA	2.79 K/W	239 cm ²
45°C	65°C	500 mA	2.23 K/W	298 cm ²

CLE 190/220mm 2500lm

ta	tp	Forward current	R _{th, hs-a}	Cooling area
25°C	65°C	350 mA		self-cooling
35°C	65°C	350 mA		self-cooling
40°C	65°C	350 mA		self-cooling
45°C	65°C	350 mA		self-cooling
25°C	65°C	500 mA		self-cooling
35°C	65°C	500 mA		self-cooling
40°C	65°C	500 mA		self-cooling
45°C	65°C	500 mA		self-cooling
25°C	65°C	600 mA		self-cooling
35°C	65°C	600 mA		self-cooling
40°C	65°C	600 mA		self-cooling
45°C	65°C	600 mA		self-cooling

CLE 315mm 4000lm

ta	tp	Forward current	R _{th, hs-a}	Cooling area
25°C	65°C	600 mA		self-cooling
35°C	65°C	600 mA		self-cooling
40°C	65°C	600 mA		self-cooling
45°C	65°C	600 mA		self-cooling
25°C	65°C	900 mA		self-cooling
35°C	65°C	900 mA		self-cooling
40°C	65°C	900 mA		self-cooling
45°C	65°C	900 mA		self-cooling

Notes

The actual cooling can differ because of the material, the structural shape, outside influences and the installation situation. A thermal connection between CLE and heat sink with heat-conducting paste or heat conducting adhesive film is absolutely necessary. Additionally the CLE has to be fixed on the heat sink with M3 screws to optimise the thermal connection.

Use of thermal interface material with thermal conductivity of $\lambda > 1 \text{ W/mK}$ and layer thickness of interface material with max. 50 μm or a similar interface material where the quotient of layer thickness and thermal conductivity $b < 50 \mu\text{mmK/W}$.

3. Installation / wiring

3.1 Electrical supply/choice of LED driver

CLE from Tridonic are not protected against overvoltages, overcurrents, overloads or short-circuit currents. Safe and reliable operation can only be guaranteed in conjunction with a LED driver which complies with the relevant standards. The use of LED drivers from Tridonic in combination with CLE guarantees the necessary protection for safe and reliable operation.

If a LED driver other than Tridonic is used, it must provide the following protection:

- Short-circuit protection
- Overload protection
- Overtemperature protection

! CLE must be supplied by a constant current LED driver. Operation with a constant voltage LED driver will lead to an irreversible damage of the module. Wrong polarity can damage the CLE.

! CLE must not be operated with nonSELV LED driver.

! CLE are basic insulated up to 60 V SELV against ground and can be mounted directly on earthed metal parts of the luminaire. If the max. output voltage of the LED driver (also against earth) is above 60 V SELV, an additional insulation between LED module and heat sink is required (for example by insulated thermal pads) or by a suitable luminaire construction. At voltages > 60 V an additional protection against direct touch (test finger) to the light emitting side of the module has to be guaranteed. This is typically achieved by means of a non removable light distributor over the module.

3.2 Wiring

CLE 160mm

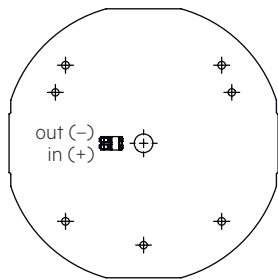

CLE 190/220/315mm

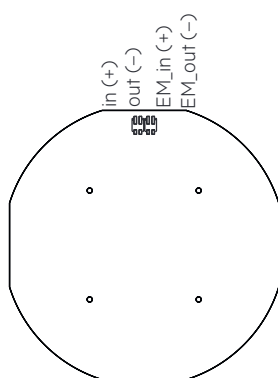

Wiring example

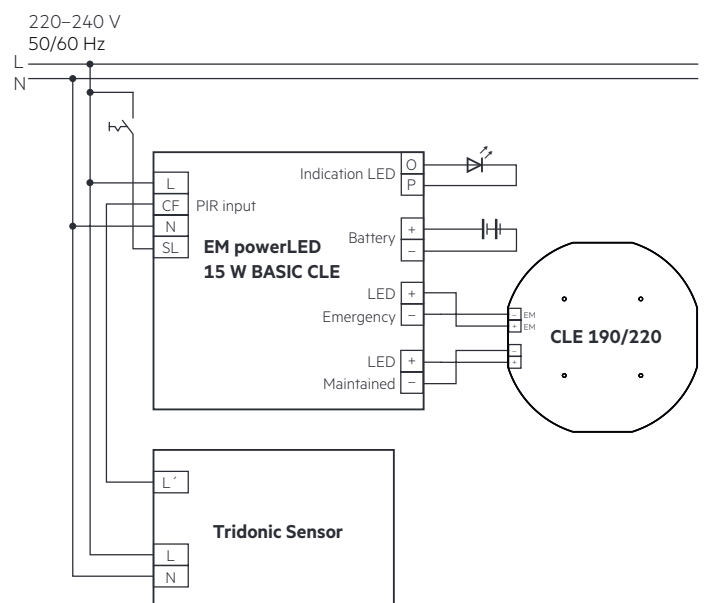
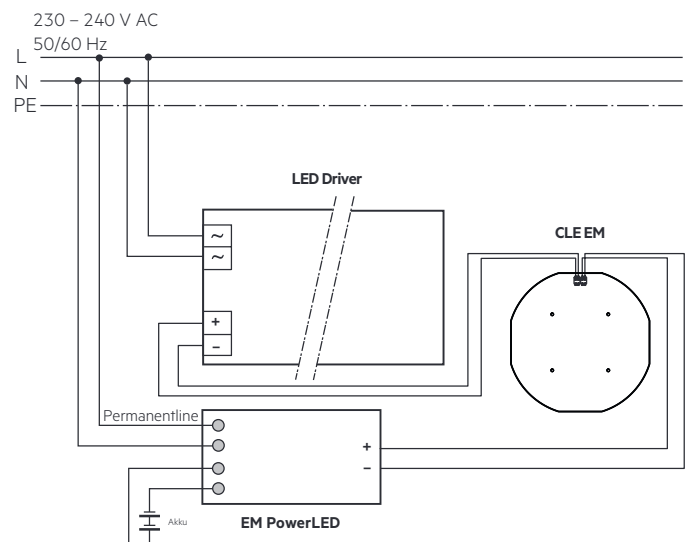
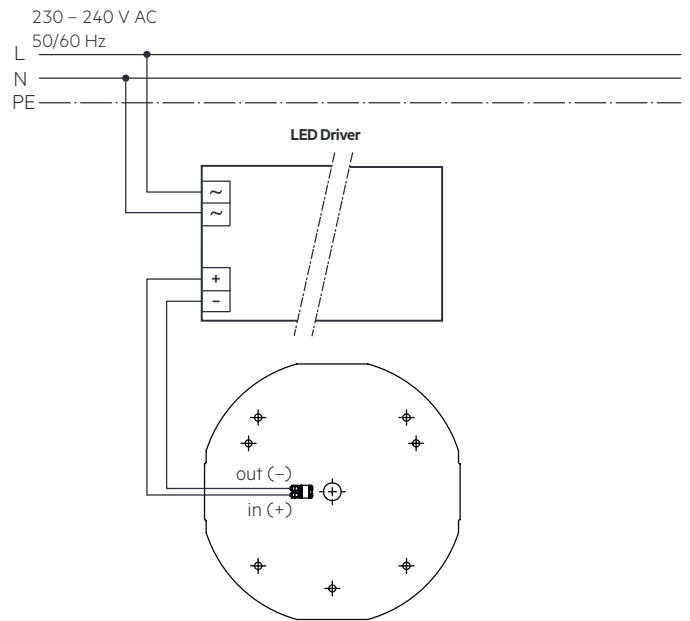

3.3 Wiring type and cross section

The wiring can be solid or stranded wire with a cross section of 0.2 to 0.75 mm². For the push-wire connection you have to strip the insulation (7–9 mm). Loosen wire through twisting and pulling.

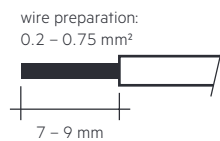

Press down the “push button” and remove the wire from front.

3.4 Mounting instruction



None of the components of the CLE (substrate, LED, electronic components etc.) may be exposed to tensile or compressive stresses.

Max. torque for fixing: 0.5 Nm.

The LED modules are mounted with 3 or 4 screws per module. In order not to damage the modules only rounded head screws and an additional plastic flat washer should be used.



Chemical substance may harm the LED module. Chemical reactions could lead to colour shift, reduced luminous flux or a total failure of the module caused by corrosion of electrical connections.

Materials which are used in LED applications (e.g. sealings, adhesives) must not produce dissolver gas. They must not be condensation curing based, acetate curing based or contain sulfur, chlorine or phthalate. Avoid corrosive atmosphere during usage and storage.

3.5 EOS/ESD safety guidelines



The device / module contains components that are sensitive to electrostatic discharge and may only be installed in the factory and on site if appropriate EOS/ESD protection measures have been taken. No special measures need be taken for devices/modules with enclosed casings (contact with the pc board not possible), just normal installation practice. Please note the requirements set out in the document EOS / ESD guidelines (Guideline_EOS_ESD.pdf) at: <http://www.tridonic.com/esd-protection>

4. Lifetime

4.1 Lifetime, lumen maintenance and failure rate

The light output of an LED module decreases over the lifetime, this is characterized with the L value.

L70 means that the LED module will give 70 % of its initial luminous flux. This value is always related to the number of operation hours and therefore defines the lifetime of an LED module.

As the L value is a statistical value and the lumen maintenance may vary over the delivered LED modules.

The B value defines the amount of modules which are below the specific L value, e.g. L70B10 means 10 % of the LED modules are below 70 % of the initial luminous flux, respectively 90 % will be above 70 % of the initial value. In addition the percentage of failed modules (fatal failure) is characterized by the C value.

The F value is the combination of the B and C value. That means for F degradation and complete failures are considered, e.g. L70F10 means 10 % of the LED modules may fail or be below 70 % of the initial luminous flux.

4.2 Lumen maintenance

Forward current	tp temperature	L90 / F10	L90 / F50	L80 / F10	L80 / F50	L70 / F10	L70 / F50
NM	40 °C	42,000 h	58,000 h	>72,000 h	>72,000 h	>72,000 h	>72,000 h
	45 °C	41,000 h	56,000 h	>72,000 h	>72,000 h	>72,000 h	>72,000 h
	50 °C	40,000 h	54,000 h	>72,000 h	>72,000 h	>72,000 h	>72,000 h
	55 °C	40,000 h	52,000 h	>72,000 h	>72,000 h	>72,000 h	>72,000 h
	60 °C	39,000 h	51,000 h	>72,000 h	>72,000 h	>72,000 h	>72,000 h
	65 °C	38,000 h	49,000 h	>72,000 h	>72,000 h	>72,000 h	>72,000 h
	70 °C	37,000 h	48,000 h	>72,000 h	>72,000 h	>72,000 h	>72,000 h
	75 °C	36,000 h	46,000 h	>72,000 h	>72,000 h	>72,000 h	>72,000 h
HO	80 °C	35,000 h	45,000 h	>72,000 h	>72,000 h	>72,000 h	>72,000 h
	40 °C	41,000 h	56,000 h	>72,000 h	>72,000 h	>72,000 h	>72,000 h
	45 °C	40,000 h	54,000 h	>72,000 h	>72,000 h	>72,000 h	>72,000 h
	50 °C	39,000 h	52,000 h	>72,000 h	>72,000 h	>72,000 h	>72,000 h
	55 °C	38,000 h	51,000 h	>72,000 h	>72,000 h	>72,000 h	>72,000 h
	60 °C	38,000 h	49,000 h	>72,000 h	>72,000 h	>72,000 h	>72,000 h
	65 °C	37,000 h	48,000 h	>72,000 h	>72,000 h	>72,000 h	>72,000 h
	70 °C	36,000 h	46,000 h	>72,000 h	>72,000 h	>72,000 h	>72,000 h
75 °C	35,000 h	45,000 h	71,000 h	>72,000 h	>72,000 h	>72,000 h	
80 °C	34,000 h	43,000 h	70,000 h	>72,000 h	>72,000 h	>72,000 h	

5. Electrical values

5.1 Typ. forward voltage vs. forward current at $t_p = 25\text{ °C}$

CLE 160mm

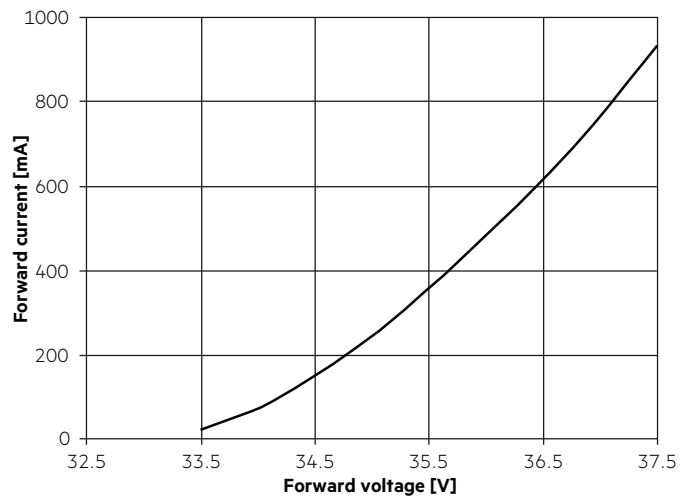

CLE 190/220mm

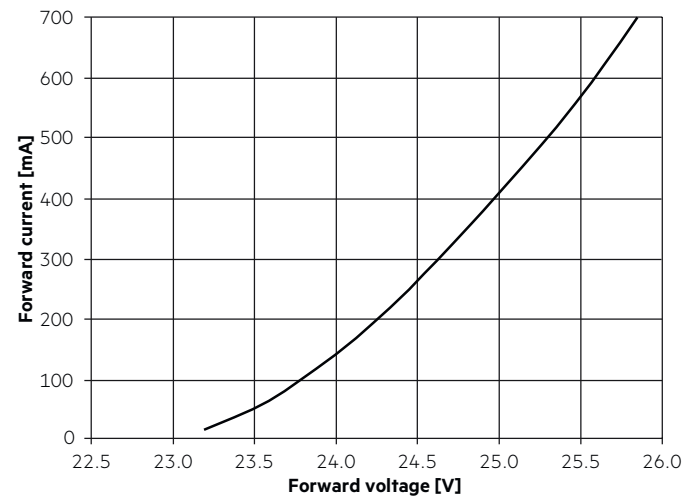

CLE 315mm

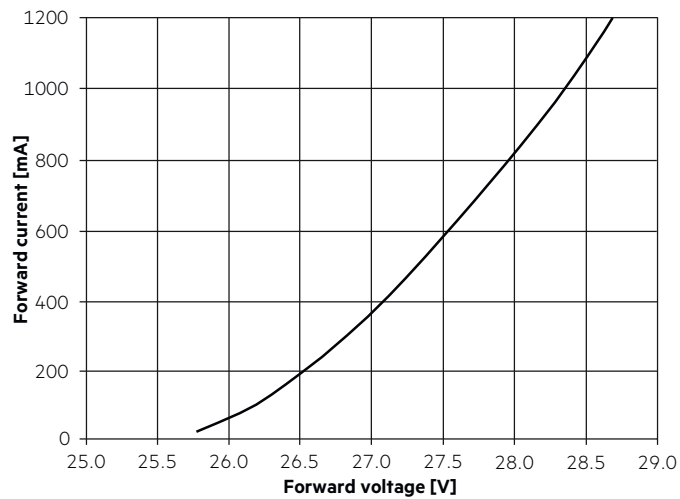

5.2 Forward voltage vs. t_p temperature

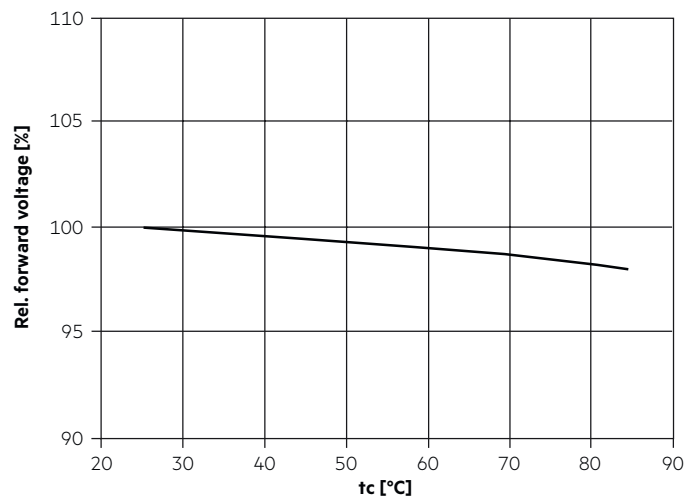

The diagrams based on statistic values. The real values can be different.

6. Photometric characteristics

6.1 Coordinates and tolerances according to CIE 1931

The specified colour coordinates are measured integral by a current impulse with Irated of the module and a duration of 100 ms.

The ambient temperature of the measurement is $t_a = 25^\circ\text{C}$.

The measurement tolerance of the colour coordinates are ± 0.01 .

3,000 K

	x0	y0
Centre	0.4338	0.4030

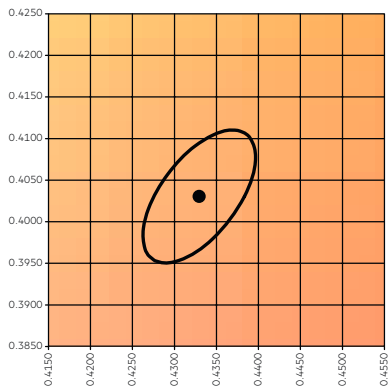

— MacAdam Ellipse: 3SDCM

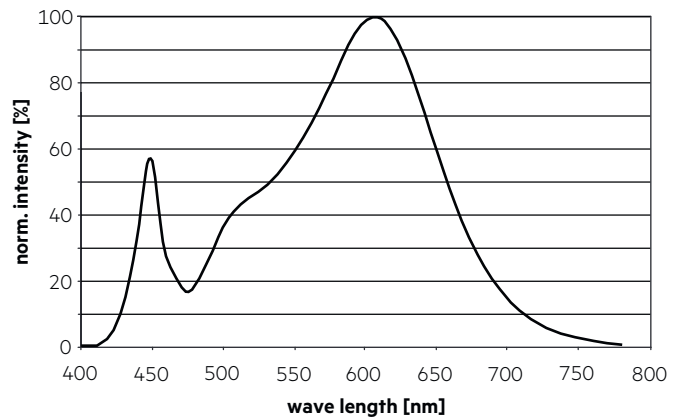

4,000 K

	x0	y0
Centre	0.3818	0.3797

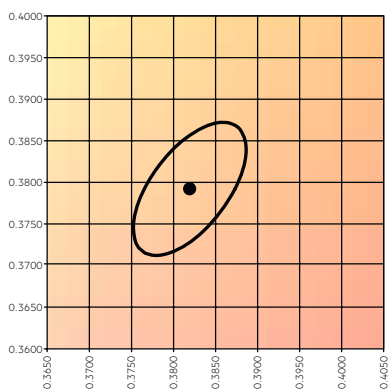

— MacAdam Ellipse: 3SDCM

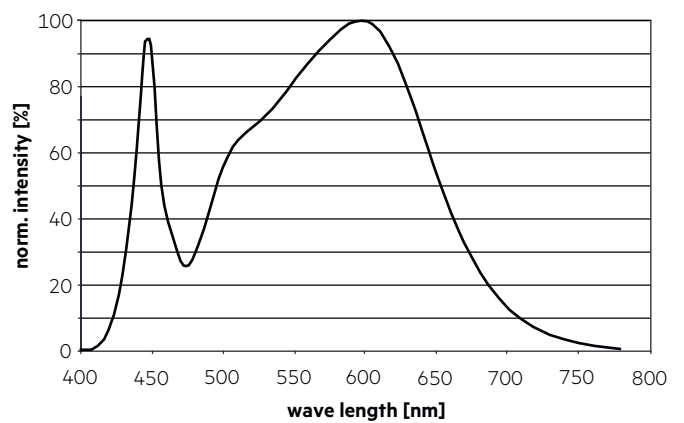

6.2 Light distribution

The optical design of the CLE product line ensures optimum homogeneity for the light distribution.

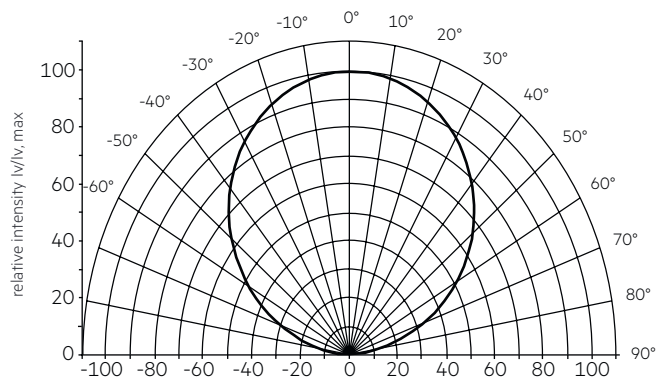

The colour temperature is measured over the complete module. The single LED light points can be outside of 3SDCM. To ensure an ideal mixture of colours and a homogeneous light distribution a suitable optic (e. g. PMMA diffuser) and a sufficient spacing between module and optic (typ. 5 cm) should be used.

6.3 Relative luminous flux vs. tc temperature

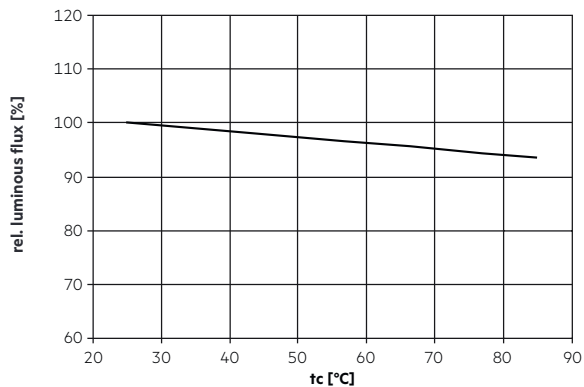

6.4 Relative luminous flux vs. operating current

CLE 160mm

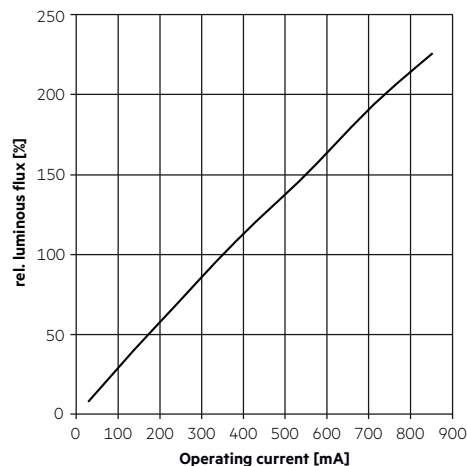

CLE 190/220mm

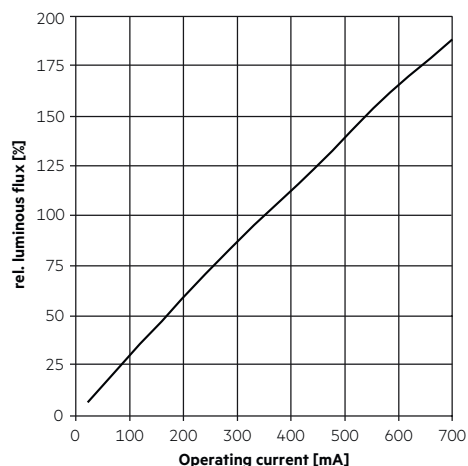

CLE 315mm

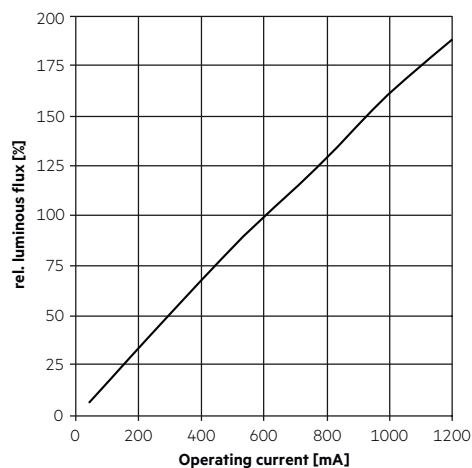

7. Miscellaneous

7.1 Additional information

Additional technical information at www.tridonic.com → Technical Data

Guarantee conditions at www.tridonic.com → Services

Lifetime declarations are informative and represent no warranty claim.