

#### EM powerLED BASIC 1 – 2 W

Combined emergency lighting LED Driver 1 – 4 W

#### Product description

- Emergency lighting LED Driver for manual testing
- For self-contained emergency lighting
- SELV for output voltage < 60 V DC
- Low profile casing (21 x 30 mm cross-section)
- 5-year guarantee

#### Properties

- Mains and emergency operation
- Constant current mode
- With either screw or clip fastening (clip-fix)
- 1, 2 or 3 h rated duration
- Selectable operating time (jumper)
- Green charge status display LED
- Output power limitation
- Automatic restart after LED replacement
- Electronic multi-level charge system
- Pulse current charging to optimize battery life
- SELV (outputs powerLED, battery, status LED, test switch)
- Polarity reversal protection for battery
- Deep discharge protection
- Very low energy consumption from the battery after activation of the deep discharge protection
- Short-circuit-proof battery connection
- Emergency lighting LEDs available

#### Batteries

- High-temperature cells: 2 Ah
- NiMH batteries
- Cs cells
- 4-year design life
- 1-year guarantee
- For battery compatibility refer to table „Battery selection“



**Standards**, page 5

**Wiring diagrams and installation examples**, page 7 and 8



Screw-fix

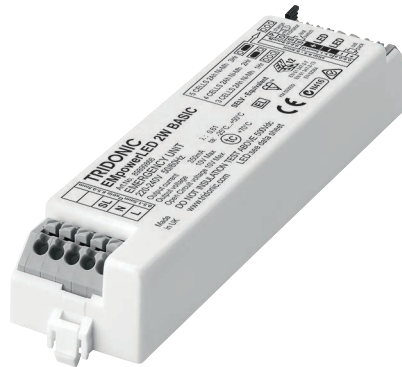

Clip-fix



### EM powerLED BASIC 1 – 2 W

Combined emergency lighting LED Driver 1 – 4 W

#### Technical data

Rated supply voltage	220 – 240 V
Mains frequency	50 / 60 Hz
Forward voltage range LED module (1 x LED)	2.8 – 3.4 V
Forward voltage range LED module (2 x LED)	5.6 – 6.8 V
Max. open circuit voltage	10 V
Time to light	0.31 s from detection of emergency event
Overvoltage protection	320 V (for 1 h)
Battery discharge current	See page 4
Max. casing temperature $t_c$	70 °C
Ambient temperature $t_a$	-25 ... +50 °C
Mains voltage changeover threshold	according to EN 60598-2-22
Type of protection	IP20

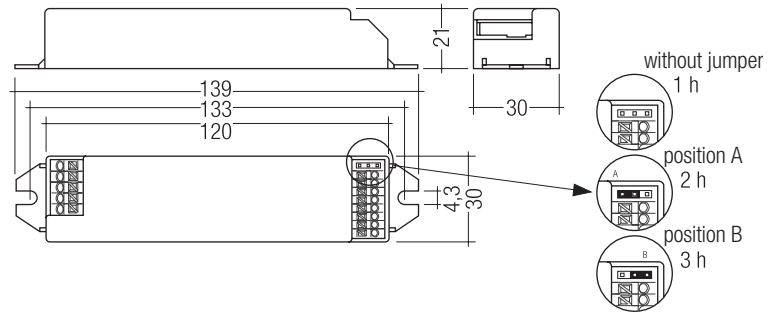

Screw-fix

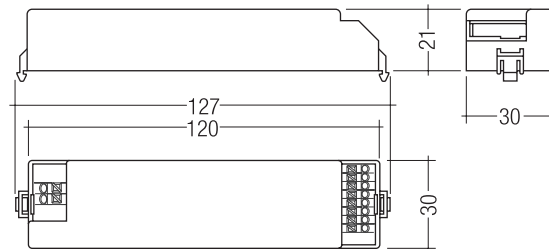

Clip-fix

#### Ordering data

Type <sup>®</sup>	Article number	Dimensions L x W x H	Packaging, carton	Packaging, pallet	Weight per pc.	Max. number of LED	Power of LED
<b>Screw fastening version</b>							
<b>EM powerLED 1 W BASIC</b>	<b>89899858</b>	139 x 30 x 21 mm	25 pc(s).	1,200 pc(s).	0.056 kg	1	1 W
<b>EM powerLED 2 W BASIC</b>	<b>89899859</b>	139 x 30 x 21 mm	25 pc(s).	1,200 pc(s).	0.056 kg	2	2 W
<b>Clip fastening version</b>							
<b>EM powerLED 1 W BASIC</b>	<b>89899865</b>	127 x 30 x 21 mm	25 pc(s).	1,200 pc(s).	0.056 kg	1	1 W
<b>EM powerLED 2 W BASIC</b>	<b>89899866</b>	127 x 30 x 21 mm	25 pc(s).	1,200 pc(s).	0.056 kg	2	2 W

#### Specific technical data

Type <sup>®</sup>	Rated duration	Typ. $\lambda$ (at 230 V, 50 Hz) <sup>①</sup>	Non-maintained operation: Mains current			Non-maintained operation: Mains power			Maintained operation: Mains current			Maintained operation: Mains power		
			Initial charge	Fast recharge	Trickle charge	Initial charge	Fast recharge	Trickle charge	Initial charge	Fast recharge	Trickle charge	Initial charge	Fast recharge	Trickle charge
<b>EM powerLED 1 W BASIC</b>	1 h	0.52c	14 mA	16 mA	13 mA	1.1 W	1.4 W	1.0 W	28 mA	30 mA	25 mA	3.2 W	3.6 W	2.8 W
<b>EM powerLED 1 W BASIC</b>	2 h	0.52c	14 mA	16 mA	13 mA	1.1 W	1.4 W	1.0 W	28 mA	30 mA	25 mA	3.2 W	3.6 W	2.8 W
<b>EM powerLED 1 W BASIC</b>	3 h	0.52c	15 mA	18 mA	13 mA	1.1 W	1.6 W	1.0 W	28 mA	30 mA	25 mA	3.2 W	3.6 W	2.8 W
<b>EM powerLED 2 W BASIC</b>	1 h	0.55c	15 mA	18 mA	13 mA	1.2 W	1.7 W	1.0 W	40 mA	45 mA	33 mA	4.8 W	5.2 W	4.0 W
<b>EM powerLED 2 W BASIC</b>	2 h	0.55c	18 mA	21 mA	13 mA	1.6 W	2.1 W	1.0 W	40 mA	45 mA	33 mA	5.0 W	5.5 W	4.0 W
<b>EM powerLED 2 W BASIC</b>	3 h	0.55c	20 mA	24 mA	13 mA	1.9 W	2.5 W	1.0 W	40 mA	45 mA	33 mA	5.2 W	5.8 W	4.0 W

<sup>①</sup> Maintained operation

<sup>®</sup> EM = Emergency

### Test switch EM2

#### Product description

- For connection to the emergency lighting unit
- For checking the device function



#### Ordering data

Type	Article number	Packaging, bag	Packaging, carton	Weight per pc.
Test switch EM 2	89805277	25 pc(s).	600 pc(s).	0.011 kg

### Status indication green LED

#### Product description

- A green LED indicates that charging current is flowing into the battery



#### Ordering data

Type	Article number	Packaging, bag	Packaging, carton	Weight per pc.
LED EM green	89899605	25 pc(s).	200 pc(s).	0.011 kg
LED EM green, ultra high brightness	89899756	25 pc(s).	800 pc(s).	0.012 kg

**Battery selection**

**EM powerLED 1-2 W BASIC, 1 / 2 / 3 h**

		Type	EM powerLED 1 W BASIC			EM powerLED 2 W BASIC		
		Article no.	89899858, 89899865			89899859, 89899866		
		Duration	1 h	2 h	3 h	1 h	2 h	3 h
		Cells	2 cells	3 cells	3 cells	3 cells	4 cells	5 cells
Technology and capacity	Design	Number of cells	Type	Article no.	Assignable batteries			
NiMH 2.2Ah Cs cells	stick	1 x 2	Accu-NiMH 2A	28002087	•			
	stick	1 x 3	Accu-NiMH 3A	28002088		•	•	•
	stick	1 x 4	Accu-NiMH 4A	28002089				•
	stick	1 x 5	Accu-NiMH 5A	28002090				•
	side by side	5 x 1	Accu-NiMH 5B	28002093				•

**Battery charge / discharge data**

**EM powerLED 1-2 W BASIC, 1 / 2 / 3 h**

		Type	EM powerLED 1 W BASIC			EM powerLED 2 W BASIC		
		Article no.	89899858, 89899865			89899859, 89899866		
		Duration	1 h	2 h	3 h	1 h	2 h	3 h
		Cells	2 cells	3 cells	3 cells	3 cells	4 cells	5 cells
Battery charge time	Initial charge	20 h						
	Fast recharge	12 h						
	Trickle charge	continuously (pulse charge)						
Charge current	Initial charge	130 mA						
	Fast recharge	210 mA						
	Trickle charge	130 mA / 0 mA (4 min. / 16 min.)						
Discharge current	1 x LED	770 mA	460 mA	460 mA	900 mA	640 mA	500 mA	
	2 x LED	–	–	–	870 mA	630 mA	500 mA	

**LED current**



**EM powerLED 1-2 W BASIC, 1 / 2 / 3 h**

		Type	EM powerLED 1 W BASIC			EM powerLED 2 W BASIC		
		Article no.	89899858, 89899865			89899859, 89899866		
LED current in emergency operation	1 x LED	350 mA			600 mA			
	2 x LED	–			350 mA			
LED current in mains operation	1 x LED	350 mA			350 mA			
	2 x LED	–			350 mA			

### Standards

- EN 61347-2-7
- EN 61347-2-13
- EN 62384
- EN 55015
- EN 61000-2-3
- EN 61547
- EN 60068-2-64
- EN 60068-2-29
- EN 60068-2-30
- according to EN 50172
- according to EN 60598-2-22

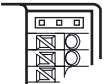
### Duration link selection

Duration	Link Position
1 hr	 without jumper
2 hr	 position A
3 hr	 position B

### Jumper selection

Module supplied with jumper in 3 hours position (position B).

The position of the link will only be read on first power up. If it is changed afterwards both the battery and mains supply must be disconnected for 10 seconds to enable the EM powerLED to read the new link position on reconnection of the battery and mains. It will lead to a false battery failure indication if the link is changed after installation without this reset.

### Life-time

Average life-time 50,000 hours under rated conditions with a failure rate of less than 10%. Average failure rate of 0.2% per 1000 operating hours.

### Technical data Accu-NiMH

#### 2.2 Ah

Battery voltage/cell	1.2 V
Cell type	Cs
Case temperature range to ensure 4 years design life	+5 °C to +55 °C
Max. short term temperature (reduced life-time)	70 °C
Max. number discharge cycles	4 cycles per year plus 30 cycles during commissioning
Max. storage time	12 months

### Batteries

Connection method: 4.8 x 0.5 mm spade tag welded to end of cell

For stick packs this connection is accessible after the battery caps have been fitted.

To inhibit inverter operation disconnect the batteries by removing the connector from the battery spade tag.

For further information refer to corresponding battery datasheet.

### Storage, installation and commissioning

Relevant information about storage conditions, installation and commissioning are provided in the battery datasheets.

### Further technical data

The EM powerLED has a unique power regulation circuit; this is designed to limit the total power drawn from the battery in the event of using LED's with a forward voltage (V<sub>f</sub>) higher than 3.4 V.

In such cases the unit will reduce the LED current in order to maintain an acceptable drain current from the battery and hence meet the required duration time. This feature enables the EM powerLED to have minimum battery count for a given range of LED's.

At a low charge state of the battery (<1.5V at the 1W driver and <3V at the 2W driver) the LED will not be driven in maintained mode via the switched line until the rated battery voltage levels are exceeded.

**Mechanical details**

Case manufactured from polycarbonate.

Glow-wire test according to EN 61347-1 with increased temperature of 850 °C passed.

LED status indicator

- Green
- Mounting hole 6.5 mm diameter, 1 – 1.6 mm thickness
- Lead length 1000 mm

Test switch

- Mounting hole 7.0 mm diameter
- Lead length 550 mm

Battery leads

- Quantity: 1 red and 1 black
- Length: 1 m
- Wire type: 0.5 mm<sup>2</sup> solid conductor
- Insulation rating: 90 °C

Battery end termination

Push on 4.8 mm receptacle to suit battery spade fitted with insulating cover

Module end termination

8.0 mm stripped insulation

Two-piece batteries are supplied with a 200 mm lead with 4.8 mm receptacles at each end and insulating covers to connect the separate sticks together.

**Recommended fixing details for clip fixing**

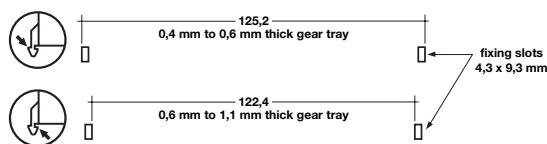

Max. torque at the clamping screw: 0.5 Nm / M4

**Isolation and electric strength testing of luminaires**

Electronic LED Drivers can be damaged by high voltage. This has to be considered during the routine testing of the luminaires in production.

According to IEC 60598-1 Annex Q (informative only!) or ENEC 303-Annex A, each luminaire should be submitted to an isolation test with 500 V<sub>DC</sub> for 1 second. This test voltage should be connected between the interconnected phase and neutral terminals and the earth terminal. The isolation resistance must be at least 2 MΩ.

As an alternative, IEC 60598-1 Annex Q describes a test of the electrical strength with 1,500 V<sub>AC</sub> (or 1,414 x 1,500 V<sub>DC</sub>). To avoid damage to the electronic LED Drivers this test must not be conducted.

**Wiring type and cross section**

**Wiring**

mains (SL, N, L)  
LED (LED +, LED -)

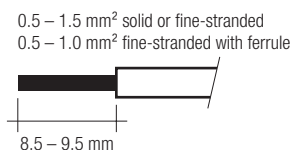

**Wiring**

batteries (Bat +, Bat -)  
test switch (switch)  
status indication LED (status K, A)

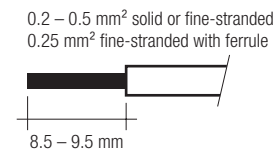

Use one wire for each terminal connector only.

**Max. lead insulation diameter**

Battery	2.1 mm
Test switch	2.1 mm
Indicator LED	2.1 mm

**Maximum lead length**

LED	3 m
status indication LED	1 m
batteries	1 m

**Release of the wiring**

Press down the “push button” and remove the cable from front.

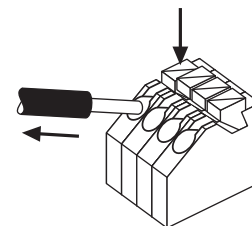

**Maximum loading of automatic circuit breakers**

Automatic circuit breaker type	B10	C10	B13	C13	B16	C16	B20	C20	Inrush current	
Installation Ø	15 mm <sup>2</sup>	15 mm <sup>2</sup>	15 mm <sup>2</sup>	15 mm <sup>2</sup>	25 mm <sup>2</sup>	25 mm <sup>2</sup>	25 mm <sup>2</sup>	25 mm <sup>2</sup>	I <sub>max</sub>	time
<b>EM powerLED 1 W BASIC</b>	90	180	130	260	130	260	130	260	10 A	120 µs
<b>EM powerLED 2 W BASIC</b>	90	180	130	260	130	260	130	260	10 A	120 µs

Wiring diagram

Wiring diagram for one LED or two LED in series

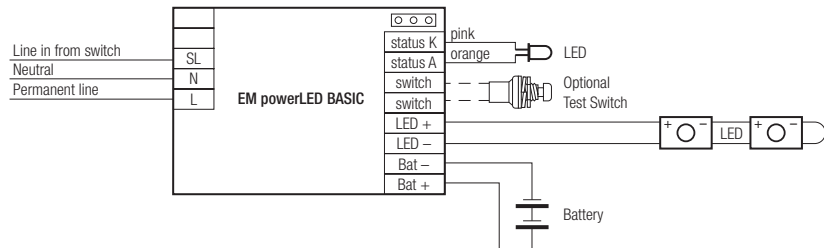

Wiring diagram for multiple LED (3–12) in parallel

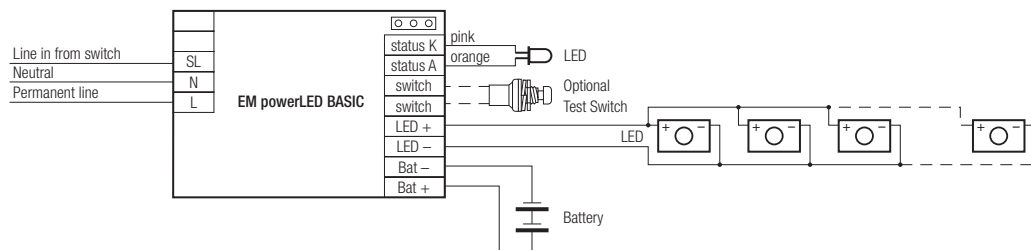

Take care that the LED is connected with the right polarity. LED that are connected to the EM powerLED devices should have a reverse polarity protection device such as a schottky diodes fitted, otherwise irreversible damage could occur if the LED is connected in reverse polarity. Any protection device must be capable of handling in excess of 700 mA.

Note: Please ensure that at the terminal of the EM powerLED module the battery negative is not connected to the negative of the LED load.

**Manually tested emergency lighting with combined LED modules for general and emergency lighting (e.g. STARK QLE CLASSIC EM, STARK LLE 24-280-1250 EM, STARK CLE CLASSIC EM, STARK SLE CLASSIC EM):**

Due to the fact that independent circuits are used for general and emergency lighting it is important that the normal supply of the mains LED Driver is switched off together with the permanent emergency supply prior to checking the operation of the emergency LEDs.

If this is not done then it may not be possible to see that the emergency LEDs are operating.

Use a circuit similar to that shown next.

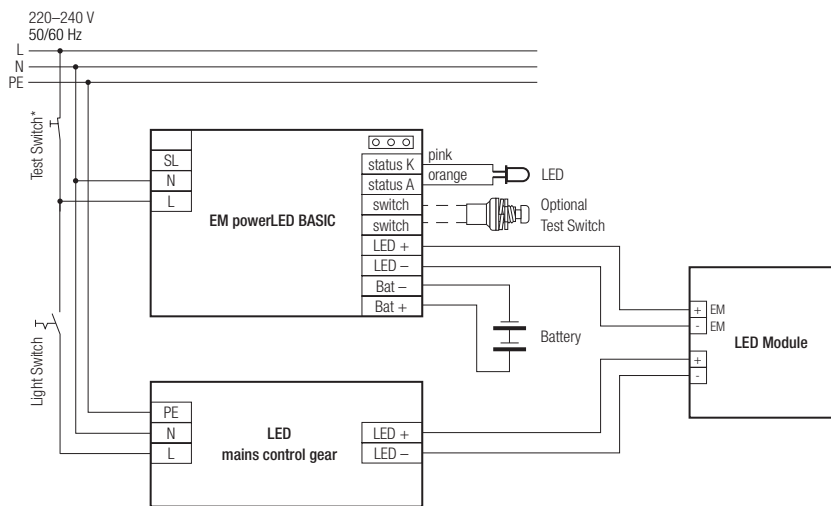

\* Use 230 V Test switch

### Simple CORRIDOR FUNCTION with EM powerLED 1-2 W

With the mains operation function of the EM powerLED 1-2 W a simple corridor function can be realised.

An external presence detector switches the mains LED Driver.

The EM powerLED 1-2 W has the switched line SL connected to permanent mains supply.

On presence both mains LED Driver and EM powerLED 1-2 W are active and driving all LEDs. With no presence the mains LED Driver is switched off by the presence detector and the EM powerLED 1-2 W stays on operating the emergency LEDs at low power.

Use a circuit similar to that shown next.

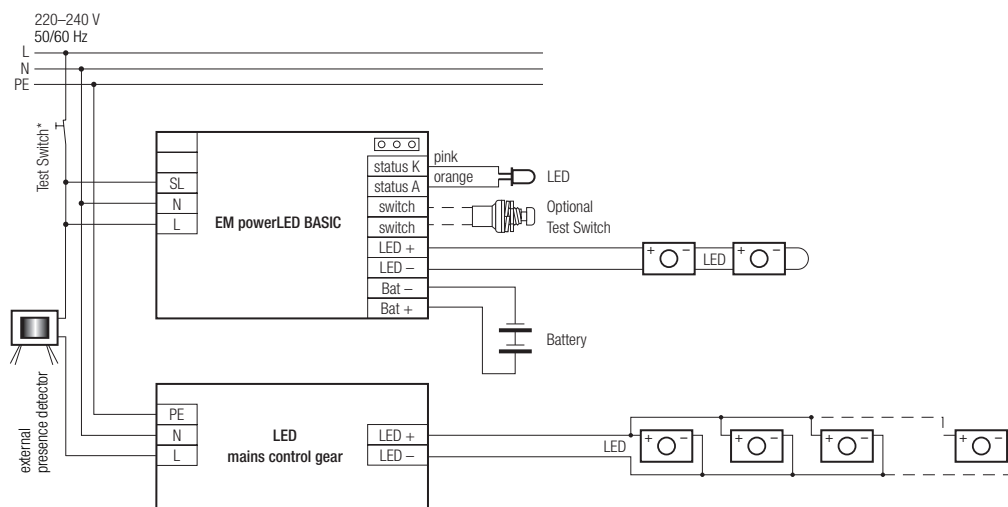

#### Wiring instructions

- The EM powerLED terminals, battery, indicator LED and test switch terminals are classified as SELV. Keep the wiring of the input terminals separated from the wiring of the SELV terminals or consider special wiring (double insulation, 6 mm creepage and clearance) when these connections should be kept SELV.
- The output to the LED is DC but has high frequency content at 125 kHz, which should be considered for good EMC compliance.
- EM powerLED leads should be separated from the mains connections and wiring for good EMC performance.
- Maximum lead length on the EM powerLED terminals is 3 m. For a good EMC performance keep the LED wiring as short as possible.
- Maximum lead length for the test switch and Indicator LED connection is 1 m. The test switch and Indicator LED wiring should be separated from the EM powerLED leads to prevent noise coupling.
- Battery leads are specified with 0.5 mm<sup>2</sup> cross section and a length of < 1.3 m.
- Switched live and unswitched live supplies must be off the same phase.
- To avoid the damage of the control gear, the wiring must be protected against short circuits to earth (sharp edged metal parts, metal cable clips, louver, etc.).

#### Maximum number of switching cycles

All LED Drivers are tested with 50,000 switching cycles. The actually achieved number of switching cycles is significantly higher.

#### Additional information

Additional technical information at [www.tridonic.com](http://www.tridonic.com) → Technical Data

Guarantee conditions at [www.tridonic.com](http://www.tridonic.com) → Services

Life-time declarations are informative and represent no warranty claim. No warranty if device was opened.