

IP20   RoHS

## TALEXengine STARK DLE TWIST CLASSIC STARK DLE TWIST

### Product description

- Complete LED Light Engine with integrated LED control gear and suitable holder
- High system efficiency  
(60 lm/W at 3,000 K and 70 lm/W at 4,000 K)
- White diffuser for a uniform and neutral appearance
- No tools required for installing the LED light engine
- For luminaire installation
- Long lifetime: 50,000 hours
- Standardised lumen packages for precise and sustainable lighting planning
- High colour rendering index (CRI > 80)
- 5-year sytem guarantee on the complete product

### Technical data

Rated supply voltage <sup>2)</sup>	220 – 240 V
AC voltage range <sup>2)</sup>	179 – 305 V
Mains frequency <sup>2)</sup>	50 / 60 Hz
Typ. current	0.071 A
Typ. $\lambda$	> 0.9
Ambient temperature $t_a$	-25 ... +40 °C
Typ. tc point <sup>3)</sup>	65 °C
Risk group (EN 62471:2008)	0
THD	45 %
Beam characteristic	103°

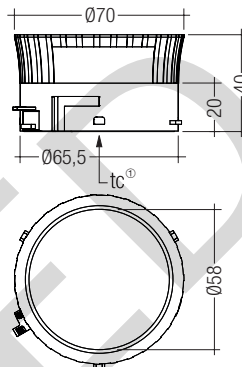
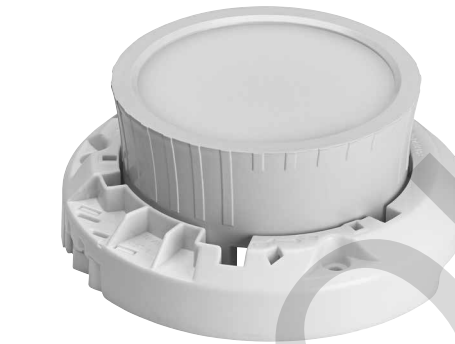

① The tc-point is situated in centre of the bottom side

### Ordering data

Type	Article number	Colour temperature	Packaging carton	Weight per pc.
STARK DLE TST F 1100 830 CLA	25000749	3,000 K	40 pc(s).	0.1 kg
STARK DLE TST F 1100 840 CLA <sup>®</sup>	25000750	4,000 K	40 pc(s).	0.1 kg



Accessories connection cable, page 2

Standards, page 3

Colour temperatures and tolerances, page 5

### Specific technical data

Type	Photometric code	Typ. luminous flux <sup>2)</sup>	Power consumption light engine	Typ. efficacy of the light engine	Colour rendering index CRI
STARK DLE TST F 1100 830 CLA	830 / 5x9	1,100 lm	18.3 W	60 lm/W	> 80
STARK DLE TST F 1100 840 CLA <sup>®</sup>	840 / 5x9	1,100 lm	15.5 W	70 lm/W	> 80

All values at  $t_a = 25$  °C,  $t_c = 65$  °C.

<sup>1)</sup> If the max. temperature limits are exceeded, the life of the system will be greatly reduced or the system may be damaged. The temperature of the TALEXengine at the tc-point is to be measured in the thermally stable state with a temperature sensor or temperature-sensitive sticker as per EN 60598-1. For the precise position of the tc point see the drawing above.

<sup>2)</sup> Tolerance range for optical and electrical data:  $\pm 10$  %.

<sup>3)</sup> Available at 02/2012.

### Product description

- Lampholder for TALEXengine STARK DLE TWIST
- Attached with M3 cheese or button head screws
- Casing: polycarbonat, white
- ZHAGA code: PHJ65D-2

### Technical data

Rated voltage	300 V
Rated current	2 A
Push terminal	0.5 – 1.5 mm <sup>2</sup>

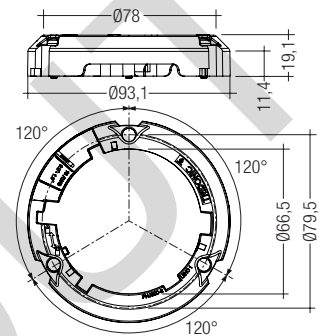

### Ordering data

Type	Article number	Packaging carton	Weight per pc.
LH 1/2 65-2	88167495	100 pc(s).	0.023 kg

**Considered standards**

- EN 55015
- EN 60589-1
- EN 60929
- EN 61000-3-2
- EN 61000-3-3
- EN 61547
- EN 62031
- EN 62384
- EN 62471
- EN 61347-1
- EN 61347-2-13

**Glow wire test according to IEC 60695-2-11**

960 °C passed.

**Photometric code**

Key for photometric code, e. g. 830 / 559

1 <sup>st</sup> digit		2 <sup>nd</sup> + 3 <sup>rd</sup> digit	4 <sup>th</sup> digit	5 <sup>th</sup> digit	6 <sup>th</sup> digit	
Code	CRI	Colour temperature in Kelvin x 100	McAdams initial	McAdams after 25% of the lifetime (max.6000h)	Lumen maintenance after 25% of the lifetime (max.6000h)	
7	67 – 76				Code	Remaining lumen
8	77 – 86				7	≥ 70 %
9	87 – ≥90				8	≥ 80 %
				9	≥ 90 %	

**Thermal design and heat sink**

The rated life of TALEX products depends to a large extent on the temperature. If the permissible temperature limits are exceeded, the life of the TALEXengine STARK DLE TWIST will be greatly reduced or the TALEXengine STARK DLE TWIST may be destroyed.

Therefore the TALEXengine STARK DLE TWIST needs to be mounted onto a heat sink.

Tridonic's excellent thermal design for the TALEXengine STARK DLE TWIST products provides the lowest thermal resistance and therefore allowing new compact designs without sacrificing quality, safety and life time.

**tc point, ambient temperature and lifetime**

The temperature at tc reference point is crucial for the light output and life time of a TALEX product.

For TALEXengine STARK DLE TWIST a tc temperature of 65 °C has to be complied in order to achieve an optimum between heat sink requirements, light output and life time.

Compliance with the maximum permissible reference temperature at the tc point must be checked under operating conditions in a thermally stable state. The maximum value must be determined under worst-case conditions for the relevant application.

The tc temperature is measured in the middle of the bottom of the LED light engine.

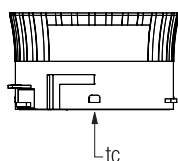
**Mounting instruction**

TALEXengine STARK DLE TWIST from Tridonic must be installed on a heat sink.

The fixing/cooling surface must be cleaned before installing the TALEX modules to remove all dirt, dust and grease.

The protective film at the back of TALEXengine STARK DLE TWIST must be removed before mounting on the heat sink.

The unit can be fixed in place with a twisting motion.

Replacement by bajonet catch is possible in every operation mode.

Take care when removing the LED light engine because the bottom may be hot (up to 65 °C).



Chemical substance may harm the LED module. Chemical reactions could lead to colour shift, reduced luminous flux or a total failure of the module caused by corrosion of electrical connections.

Materials which are used in LED applications (e.g. sealings, adhesives) must not produce dissolver gas. They must not be condensation curing based, acetate curing based or contain sulfur, chlorine or phthalate. Avoid corrosive atmosphere during usage and storage.

**Heat sink values****TALEXengine STARK DLE TWIST CLASSIC 1,100 lm**

ta	tc	R <sub>th, hs-a</sub>	heat sink surface
25 °C	65 °C	2.2 K/W	524 cm <sup>2</sup>
35 °C	65 °C	1.6 K/W	920 cm <sup>2</sup>
40 °C	65 °C	1.4 K/W	1,595 cm <sup>2</sup>

**Notes**

Values valid for: natural convection, heat sink material: aluminium ≥ 1 mm thick, R<sub>th, hs-a</sub> = required thermal resistance of heat sink

The actual cooling surface can differ because of the material, the structural shape, outside influences and the installation situation. A thermal connection between TALEX/module STARK DLE and heat sink with heat-conducting paste or heat conducting adhesive film is absolutely necessary.

Check leaflet "STARK DLE TWIST" for recommended heat sinks, see [www.tridonic.com](http://www.tridonic.com)

**Thermal behaviour**

storage temperature	-40 ... +80 °C
operating temperature	-25 ... +40 °C
tc max. (at typ. current)	65 °C
max. rel. humidity	0 ... 80 %

The LED light engine have to be within the specified operating temperature range (ta) before they can be operated.

### Lumen maintenance

tc temperature in °C	luminous flux in %	operating time in h
45	80	40.000
	70	60.000
	50	100.000
55	80	35.000
	70	55.000
	50	95.000
65	80	30.000
	70	50.000
	50	90.000

### Relative luminous flux

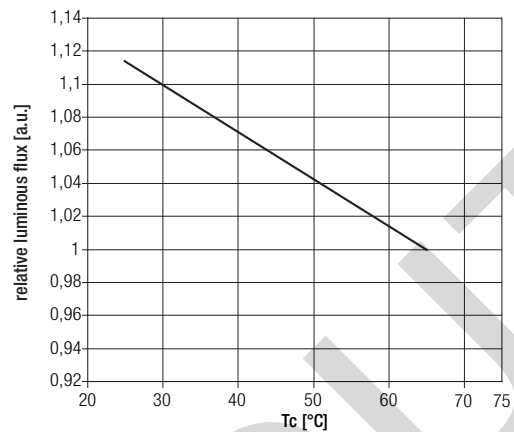

The diagrams based on statistic values.  
The real values can be different.

### Wiring

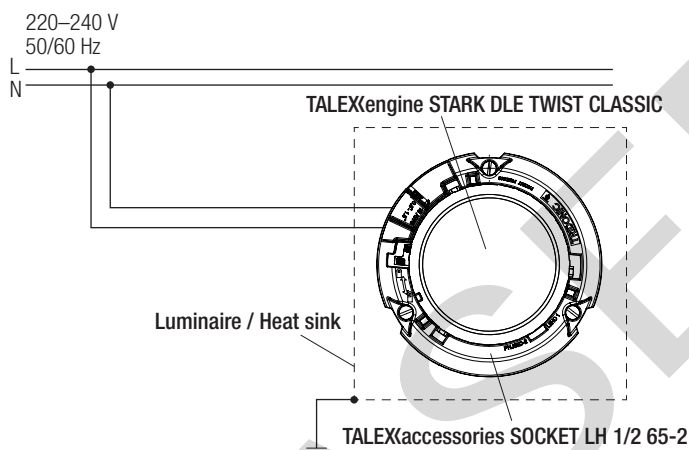

### Wiring type and cross section

The wiring can be solid cable with a cross section of 0.5 to 1.5 mm<sup>2</sup>.  
For the push-wire connection you have to strip the insulation (8 – 9.5 mm).

wire preparation:  
0.5 – 1.5 mm<sup>2</sup>

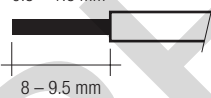

### Maximum loading of automatic circuit breakers

Automatic circuit breaker type	C10	C13	C16	C20	B10	B13	B16	B20	Inrush current
Installation Ø	1.5 mm <sup>2</sup>	1.5 mm <sup>2</sup>	1.5 mm <sup>2</sup>	2.5 mm <sup>2</sup>	1.5 mm <sup>2</sup>	1.5 mm <sup>2</sup>	1.5 mm <sup>2</sup>	2.5 mm <sup>2</sup>	I <sub>max</sub> time
STARK DLE TST F 1100 830 CLA	125	162	200	250	125	162	200	250	5 A 380 µs
STARK DLE TST F 1100 840 CLA	125	162	200	250	125	162	200	250	5 A 380 µs

### Optical characteristics TALEX(module STARK DLE

The optical design of the TALEX(module STARK DLE product line ensures optimum homogeneity for the light distribution.

#### TALEX(module STARK DLE CLASSIC 103°: Light distribution

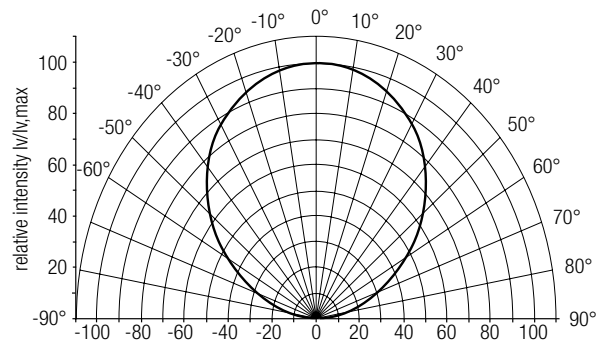

For further information see Design-in Guide, 3D data and photometric data on [www.tridonic.com](http://www.tridonic.com) or on request.

### Coordinates and tolerances according to CIE 1931

The specified colour coordinates are measured by a current impulse with typical values of module and a duration of 100 ms.  
The ambient temperature of the measurement is  $t_a = 25\text{ °C}$ .  
The measurement tolerance of the colour coordinates are  $\pm 0.01$ .

#### 3,000 K

	x0	y0
Centre	0,4344	0,4032

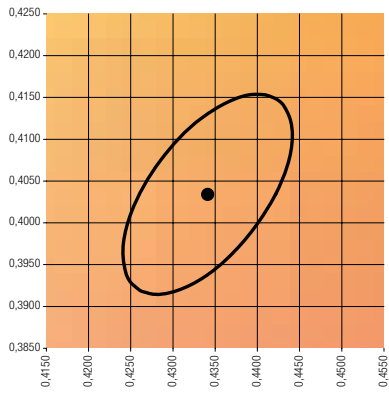

— MacAdam Ellipse: 5SDCM

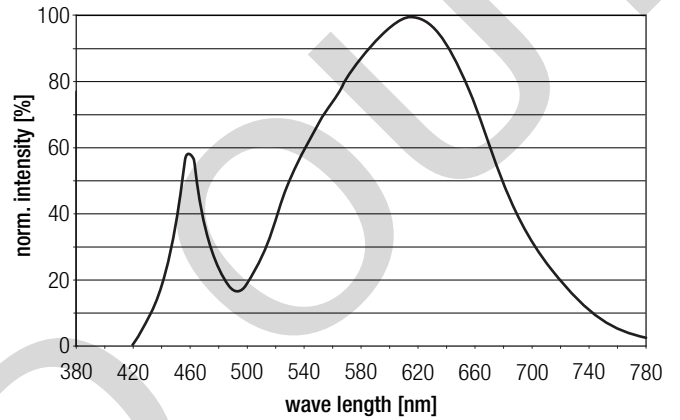

#### 4,000 K

	x0	y0
Mittelpunkt	0,3828	0,3803

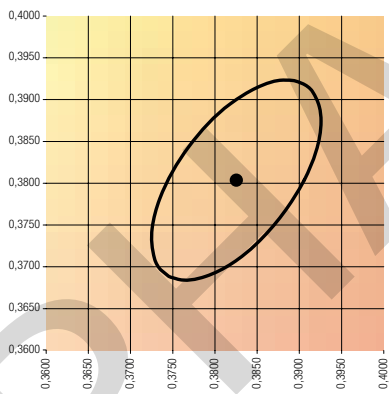

— MacAdam Ellipse: 5SDCM

