



### Module CLE G3 ADV

Modules CLE

#### Product description

- Ideal for ceiling-mounted and wallmounted luminaires
- LED system solution consisting of the LED module, the control gear with integrated emergency function and SWITCH sensor
- Based on circular and TC-DD fluorescent lamps
- Efficacy of the module up to 181 lm/W
- SO version is compatible with SWITCH Sensor HF 5BP
- Integrated separate emergency LEDs with CLE G3 190/220/315 controlled by EM powerLED
- High colour rendering index CRI > 80
- Small colour tolerance MacAdam 3<sup>®</sup>
- Small luminous flux tolerances
- Colour temperatures 3,000 and 4,000 K
- Push terminals for quick and simple wiring
- Simple installation (e.g. screws)
- Long life-time: 50,000 hours
- 5-year guarantee



**Standards**, page 6

**For colour temperatures and tolerances**, page 10



CLE G3 160mm 3000lm ADV

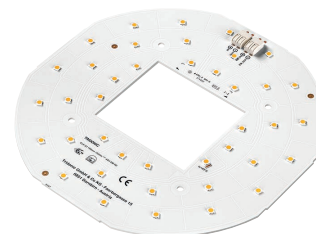

CLE G3 190mm 1500lm ADV EM SO

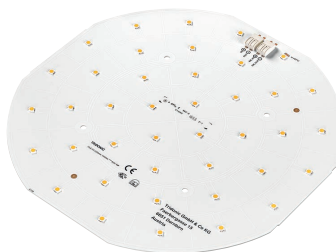

CLE G3 220mm 1500lm ADV EM

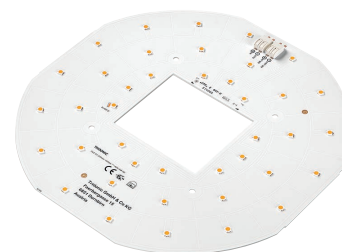

CLE G3 220mm 1500lm ADV EM SO



CLE G3 315mm 4000lm ADV EM

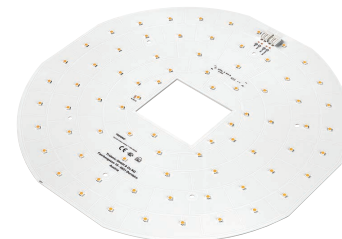

CLE G3 315mm 4000lm ADV EM SO

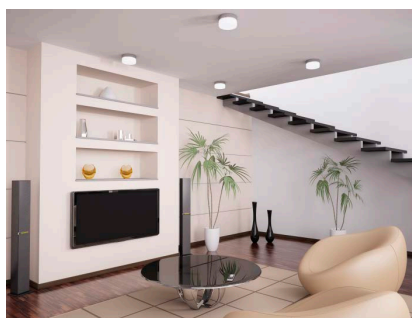

Typische Anwendung



### Module CLE G3 ADV

Modules CLE

#### Technical data

Beam characteristic	120°
Ambient temperature range	-25 ... +45 °C
tp rated	65 °C
tc	85 °C
Irated for CLE 160mm	350 mA
Irated for CLE 190/220mm	350 mA
Irated for CLE 315mm	700 mA
I <sub>max</sub> for CLE 160mm	850 mA
I <sub>max</sub> for CLE 190/220mm	700 mA
I <sub>max</sub> for CLE 315mm	1,200 mA
Max. permissible LF current ripple for CLE 160mm	1,000 mA
Max. permissible LF current ripple for CLE 190/220mm	800 mA
Max. permissible LF current ripple for CLE 315mm	1,400 mA
Max. permissible peak current for CLE 160mm	1,200 mA / max. 10 ms
Max. permissible peak current for CLE 190/220mm	960 mA / max. 10 ms
Max. permissible peak current for CLE 315mm	1,680 mA / max. 10 ms
Max. working voltage for insulation <sup>①</sup>	60 V SELV
Insulation test voltage	0.5 kV
ESD classification	severity level 1
Risk group (EN 62471:2008)	RG0
Type of protection	IPO0

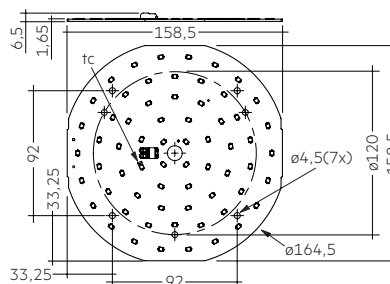

CLE G3 160mm 3000lm ADV

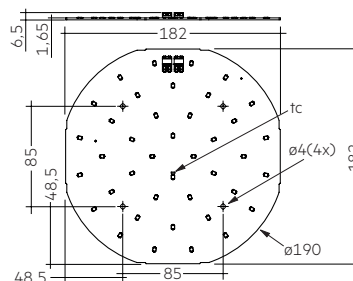

CLE G3 190mm 1500lm EM ADV

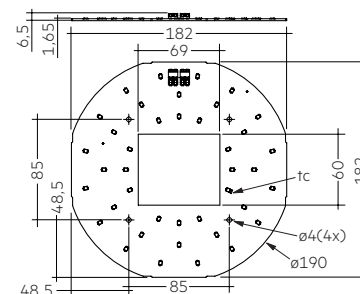

CLE G3 190mm 1500lm EM SO ADV

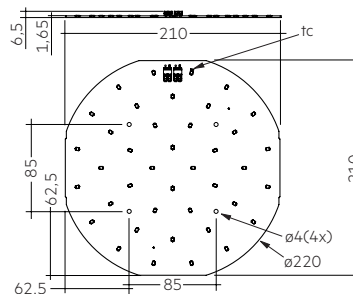

CLE G3 220mm 1500lm EM ADV

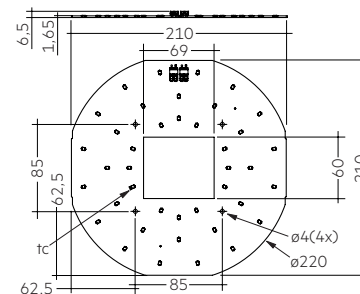

CLE G3 220mm 1500lm EM SO ADV

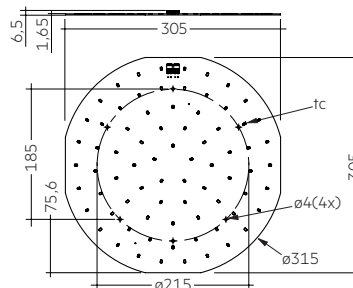

CLE G3 315mm 4000lm EM ADV

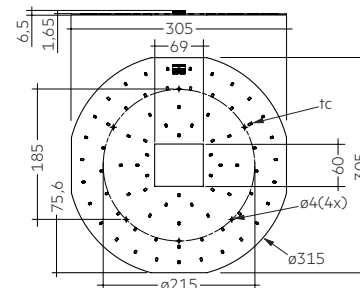

CLE G3 315mm 4000lm EM SO ADV

## Module CLE G3 ADV

Modules CLE

## Ordering data

Type	Article number	Colour temperature	Packaging, carton	Weight per pc.
CLE G3 160mm 3000lm 830 ADV	89602856	3,000 K	50 pc(s).	0.059 kg
CLE G3 160mm 3000lm 840 ADV	89602857	4,000 K	50 pc(s).	0.059 kg
CLE G3 190mm 1500lm 830 ADV EM	89602858	3,000 K	50 pc(s).	0.075 kg
CLE G3 190mm 1500lm 840 ADV EM	89602859	4,000 K	50 pc(s).	0.075 kg
CLE G3 190mm 1500lm 830 ADV EM SO	89602860	3,000 K	50 pc(s).	0.064 kg
CLE G3 190mm 1500lm 840 ADV EM SO	89602861	4,000 K	50 pc(s).	0.064 kg
CLE G3 220mm 1500lm 830 ADV EM	89602862	3,000 K	50 pc(s).	0.099 kg
CLE G3 220mm 1500lm 840 ADV EM	89602863	4,000 K	50 pc(s).	0.099 kg
CLE G3 220mm 1500lm 830 ADV EM SO	89602864	3,000 K	50 pc(s).	0.088 kg
CLE G3 220mm 1500lm 840 ADV EM SO	89602865	4,000 K	50 pc(s).	0.088 kg
CLE G3 315mm 4000lm 830 ADV EM	89602866	3,000 K	10 pc(s).	0.208 kg
CLE G3 315mm 4000lm 840 ADV EM	89602867	4,000 K	10 pc(s).	0.208 kg
CLE G3 315mm 4000lm 830 ADV EM SO	89602868	3,000 K	10 pc(s).	0.199 kg
CLE G3 315mm 4000lm 840 ADV EM SO	89602869	4,000 K	10 pc(s).	0.199 kg

## Specific technical data

Type <sup>①</sup>	Photo-metric code	Typ. luminous flux at tp = 25 °C <sup>②</sup>	Typ. luminous flux at tp = 65 °C <sup>②</sup>	Typ. forward current	Min. forward voltage at tp = 65 °C	Max. forward voltage at tp = 25 °C	Typ. power consumption at tp = 65 °C <sup>③</sup>	Luminous efficacy module at tp = 25 °C	Luminous efficacy module at tp = 65 °C	Luminous efficacy system at tp = 65 °C	Colour rendering index CRI
<b>CLE G3 160mm – Operating mode HE</b>											
CLE G3 160mm 3000lm 830 ADV	830/359	2,130 lm	1,980 lm	350 mA	34.1 V	39.0 V	12.6 W	164 lm/W	157 lm/W	141 lm/W	> 80
CLE G3 160mm 3000lm 840 ADV	840/359	2,350 lm	2,190 lm	350 mA	34.1 V	39.0 V	12.6 W	181 lm/W	173 lm/W	156 lm/W	> 80
<b>CLE G3 160mm – Operating mode HO</b>											
CLE G3 160mm 3000lm 830 ADV	830/359	2,950 lm	2,750 lm	500 mA	35.4 V	40.3 V	18.7 W	153 lm/W	147 lm/W	132 lm/W	> 80
CLE G3 160mm 3000lm 840 ADV	840/359	3,260 lm	3,040 lm	500 mA	35.4 V	40.3 V	18.7 W	170 lm/W	162 lm/W	146 lm/W	> 80

<sup>①</sup> Tolerance range for optical and electrical data: ±10 %.

<sup>②</sup> If mounted with M4 screws and plastic washers.

<sup>③</sup> Integrated measurement over the whole module.

<sup>④</sup> HE ... high efficiency, HO ... high output.

## Specific technical data

Type <sup>①</sup>	Photo-metric code	Typ. luminous flux at tp = 25 °C <sup>②</sup>	Typ. luminous flux at tp = 65 °C <sup>②</sup>	Typ. forward current	Min. forward voltage at tp = 65 °C	Max. forward voltage at tp = 25 °C	Typ. power consumption at tp = 65 °C <sup>③</sup>	Luminous efficacy module at tp = 25 °C	Luminous efficacy module at tp = 65 °C	Luminous efficacy system at tp = 65 °C	Colour rendering index CRI
<b>CLE G3 190/220mm – Operating mode HE</b>											
CLE G3 190mm 1500lm 830 ADV EM	830/359	1,460 lm	1,360 lm	350 mA	24.2 V	27.5 V	8.9 W	159 lm/W	152 lm/W	137 lm/W	> 80
CLE G3 220mm 1500lm 830 ADV EM	830/359	1,460 lm	1,360 lm	350 mA	24.2 V	27.5 V	8.9 W	159 lm/W	152 lm/W	137 lm/W	> 80
CLE G3 190mm 1500lm 840 ADV EM	840/359	1,610 lm	1,510 lm	350 mA	24.2 V	27.5 V	8.9 W	175 lm/W	169 lm/W	152 lm/W	> 80
CLE G3 220mm 1500lm 840 ADV EM	840/359	1,610 lm	1,510 lm	350 mA	24.2 V	27.5 V	8.9 W	175 lm/W	169 lm/W	152 lm/W	> 80
CLE G3 190mm 1500lm 830 ADV EM SO	830/359	1,460 lm	1,360 lm	350 mA	24.2 V	27.5 V	8.9 W	159 lm/W	152 lm/W	137 lm/W	> 80
CLE G3 220mm 1500lm 830 ADV EM SO	830/359	1,460 lm	1,360 lm	350 mA	24.2 V	27.5 V	8.9 W	159 lm/W	152 lm/W	137 lm/W	> 80
CLE G3 190mm 1500lm 840 ADV EM SO	840/359	1,610 lm	1,510 lm	350 mA	24.2 V	27.5 V	8.9 W	175 lm/W	169 lm/W	152 lm/W	> 80
CLE G3 220mm 1500lm 840 ADV EM SO	840/359	1,610 lm	1,510 lm	350 mA	24.2 V	27.5 V	8.9 W	175 lm/W	169 lm/W	152 lm/W	> 80
<b>CLE G3 190/220mm – Operating mode HO</b>											
CLE G3 190mm 1500lm 830 ADV EM	830/359	2,000 lm	1,860 lm	500 mA	25.3 V	28.7 V	13.3 W	146 lm/W	139 lm/W	125 lm/W	> 80
CLE G3 220mm 1500lm 830 ADV EM	830/359	2,000 lm	1,860 lm	500 mA	25.3 V	28.7 V	13.3 W	146 lm/W	139 lm/W	125 lm/W	> 80
CLE G3 190mm 1500lm 840 ADV EM	840/359	2,200 lm	2,060 lm	500 mA	25.3 V	28.7 V	13.3 W	155 lm/W	149 lm/W	134 lm/W	> 80
CLE G3 220mm 1500lm 840 ADV EM	840/359	2,200 lm	2,060 lm	500 mA	25.3 V	28.7 V	13.3 W	155 lm/W	149 lm/W	134 lm/W	> 80
CLE G3 190mm 1500lm 830 ADV EM SO	830/359	2,000 lm	1,860 lm	500 mA	25.3 V	28.7 V	13.3 W	146 lm/W	139 lm/W	125 lm/W	> 80
CLE G3 220mm 1500lm 830 ADV EM SO	830/359	2,000 lm	1,860 lm	500 mA	25.3 V	28.7 V	13.3 W	146 lm/W	139 lm/W	125 lm/W	> 80
CLE G3 190mm 1500lm 840 ADV EM SO	840/359	2,200 lm	2,060 lm	500 mA	25.3 V	28.7 V	13.3 W	155 lm/W	149 lm/W	134 lm/W	> 80
CLE G3 220mm 1500lm 840 ADV EM SO	840/359	2,200 lm	2,060 lm	500 mA	25.3 V	28.7 V	13.3 W	155 lm/W	149 lm/W	134 lm/W	> 80
<b>CLE G3 190/220mm – Emergency operation at 320 mA (EM powerLED NM 1 W BASIC, EM powerLED 15 W BASIC CLE NiCd)</b>											
CLE G3 190mm 1500lm 830 ADV EM	830/359	150 lm	140 lm	320 mA	-	-	-	-	-	-	> 80
CLE G3 220mm 1500lm 830 ADV EM	830/359	150 lm	140 lm	320 mA	-	-	-	-	-	-	> 80
CLE G3 190mm 1500lm 840 ADV EM	840/359	165 lm	155 lm	320 mA	-	-	-	-	-	-	> 80
CLE G3 220mm 1500lm 840 ADV EM	840/359	165 lm	155 lm	320 mA	-	-	-	-	-	-	> 80
CLE G3 190mm 1500lm 830 ADV EM SO	830/359	150 lm	140 lm	320 mA	-	-	-	-	-	-	> 80
CLE G3 220mm 1500lm 830 ADV EM SO	830/359	150 lm	140 lm	320 mA	-	-	-	-	-	-	> 80
CLE G3 190mm 1500lm 840 ADV EM SO	840/359	165 lm	155 lm	320 mA	-	-	-	-	-	-	> 80
CLE G3 220mm 1500lm 840 ADV EM SO	840/359	165 lm	155 lm	320 mA	-	-	-	-	-	-	> 80
<b>CLE G3 190/220mm – Emergency operation at 350 mA (EM powerLED 1 W)</b>											
CLE G3 190mm 1500lm 830 ADV EM	830/359	160 lm	150 lm	350 mA	-	-	-	-	-	-	> 80
CLE G3 220mm 1500lm 830 ADV EM	830/359	160 lm	150 lm	350 mA	-	-	-	-	-	-	> 80
CLE G3 190mm 1500lm 840 ADV EM	840/359	180 lm	165 lm	350 mA	-	-	-	-	-	-	> 80
CLE G3 220mm 1500lm 840 ADV EM	840/359	180 lm	165 lm	350 mA	-	-	-	-	-	-	> 80
CLE G3 190mm 1500lm 830 ADV EM SO	830/359	160 lm	150 lm	350 mA	-	-	-	-	-	-	> 80
CLE G3 220mm 1500lm 830 ADV EM SO	830/359	160 lm	150 lm	350 mA	-	-	-	-	-	-	> 80
CLE G3 190mm 1500lm 840 ADV EM SO	840/359	180 lm	165 lm	350 mA	-	-	-	-	-	-	> 80
CLE G3 220mm 1500lm 840 ADV EM SO	840/359	180 lm	165 lm	350 mA	-	-	-	-	-	-	> 80
<b>CLE G3 190/220mm – Emergency operation at 400 mA (EM powerLED 15 W BASIC CLE NiMH)</b>											
CLE G3 190mm 1500lm 830 ADV EM	830/359	180 lm	170 lm	400 mA	-	-	-	-	-	-	> 80
CLE G3 220mm 1500lm 830 ADV EM	830/359	180 lm	170 lm	400 mA	-	-	-	-	-	-	> 80
CLE G3 190mm 1500lm 840 ADV EM	840/359	200 lm	185 lm	400 mA	-	-	-	-	-	-	> 80
CLE G3 220mm 1500lm 840 ADV EM	840/359	200 lm	185 lm	400 mA	-	-	-	-	-	-	> 80
CLE G3 190mm 1500lm 830 ADV EM SO	830/359	180 lm	170 lm	400 mA	-	-	-	-	-	-	> 80
CLE G3 220mm 1500lm 830 ADV EM SO	830/359	180 lm	170 lm	400 mA	-	-	-	-	-	-	> 80
CLE G3 190mm 1500lm 840 ADV EM SO	840/359	200 lm	185 lm	400 mA	-	-	-	-	-	-	> 80
CLE G3 220mm 1500lm 840 ADV EM SO	840/359	200 lm	185 lm	400 mA	-	-	-	-	-	-	> 80
<b>CLE G3 190/220mm – Emergency operation at 600 mA (EM powerLED 2 W)</b>											
CLE G3 190mm 1500lm 830 ADV EM	830/359	260 lm	245 lm	600 mA	-	-	-	-	-	-	> 80
CLE G3 220mm 1500lm 830 ADV EM	830/359	260 lm	245 lm	600 mA	-	-	-	-	-	-	> 80
CLE G3 190mm 1500lm 840 ADV EM	840/359	290 lm	270 lm	600 mA	-	-	-	-	-	-	> 80
CLE G3 220mm 1500lm 840 ADV EM	840/359	290 lm	270 lm	600 mA	-	-	-	-	-	-	> 80
CLE G3 190mm 1500lm 830 ADV EM SO	830/359	260 lm	245 lm	600 mA	-	-	-	-	-	-	> 80
CLE G3 220mm 1500lm 830 ADV EM SO	830/359	260 lm	245 lm	600 mA	-	-	-	-	-	-	> 80
CLE G3 190mm 1500lm 840 ADV EM SO	840/359	290 lm	270 lm	600 mA	-	-	-	-	-	-	> 80
CLE G3 220mm 1500lm 840 ADV EM SO	840/359	290 lm	270 lm	600 mA	-	-	-	-	-	-	> 80

① Tolerance range for optical and electrical data: ±10 %.

② If mounted with M4 screws and plastic washers.

③ Integrated measurement over the whole module.

④ HE ... high efficiency, HO ... high output.

## Specific technical data

Type <sup>Ⓢ</sup>	Photo-metric code	Typ. luminous flux at tp = 25 °C <sup>Ⓢ</sup>	Typ. luminous flux at tp = 65 °C <sup>Ⓢ</sup>	Typ. forward current	Min. forward voltage at tp = 65 °C	Max. forward voltage at tp = 25 °C	Typ. power consumption at tp = 65 °C <sup>Ⓢ</sup>	Luminous efficacy module at tp = 25 °C	Luminous efficacy module at tp = 65 °C	Luminous efficacy system at tp = 65 °C	Colour rendering index CRI
<b>CLE G3 315mm – Operating mode HE</b>											
<b>CLE G3 315mm 4000lm 830 ADV EM</b>	830/359	2,790 lm	2,600 lm	600 mA	26.8 V	30.5 V	17.0 W	160 lm/W	153 lm/W	138 lm/W	> 80
<b>CLE G3 315mm 4000lm 840 ADV EM</b>	840/359	3,080 lm	2,870 lm	600 mA	26.8 V	30.5 V	17.0 W	176 lm/W	169 lm/W	152 lm/W	> 80
<b>CLE G3 315mm 4000lm 830 ADV EM SO</b>	830/359	2,790 lm	2,600 lm	600 mA	26.8 V	30.5 V	17.0 W	160 lm/W	153 lm/W	138 lm/W	> 80
<b>CLE G3 315mm 4000lm 840 ADV EM SO</b>	840/359	3,080 lm	2,870 lm	600 mA	26.8 V	30.5 V	17.0 W	176 lm/W	169 lm/W	152 lm/W	> 80
<b>CLE G3 315mm – Operating mode HO</b>											
<b>CLE G3 315mm 4000lm 830 ADV EM</b>	830/359	3,980 lm	3,720 lm	900 mA	25.4 V	32.0 V	26.7 W	145 lm/W	139 lm/W	125 lm/W	> 80
<b>CLE G3 315mm 4000lm 840 ADV EM</b>	840/359	4,400 lm	4,100 lm	900 mA	25.4 V	32.0 V	26.7 W	160 lm/W	153 lm/W	138 lm/W	> 80
<b>CLE G3 315mm 4000lm 830 ADV EM SO</b>	830/359	3,980 lm	3,720 lm	900 mA	25.4 V	32.0 V	26.7 W	145 lm/W	139 lm/W	125 lm/W	> 80
<b>CLE G3 315mm 4000lm 840 ADV EM SO</b>	840/359	4,400 lm	4,100 lm	900 mA	25.4 V	32.0 V	26.7 W	160 lm/W	153 lm/W	138 lm/W	> 80
<b>CLE G3 315mm – Emergency operation at 600 mA (EM powerLED 2 W)</b>											
<b>CLE G3 315mm 4000lm 830 ADV EM</b>	830/359	270 lm	255 lm	600 mA	–	–	–	–	–	–	> 80
<b>CLE G3 315mm 4000lm 840 ADV EM</b>	840/359	300 lm	280 lm	600 mA	–	–	–	–	–	–	> 80
<b>CLE G3 315mm 4000lm 830 ADV EM SO</b>	830/359	270 lm	255 lm	600 mA	–	–	–	–	–	–	> 80
<b>CLE G3 315mm 4000lm 840 ADV EM SO</b>	840/359	300 lm	280 lm	600 mA	–	–	–	–	–	–	> 80
<b>CLE G3 315mm – Emergency operation at 1,000 mA (EM powerLED 4 W)</b>											
<b>CLE G3 315mm 4000lm 830 ADV EM</b>	830/359	430 lm	400 lm	1,000 mA	–	–	–	–	–	–	> 80
<b>CLE G3 315mm 4000lm 840 ADV EM</b>	840/359	475 lm	440 lm	1,000 mA	–	–	–	–	–	–	> 80
<b>CLE G3 315mm 4000lm 830 ADV EM SO</b>	830/359	430 lm	400 lm	1,000 mA	–	–	–	–	–	–	> 80
<b>CLE G3 315mm 4000lm 840 ADV EM SO</b>	840/359	475 lm	440 lm	1,000 mA	–	–	–	–	–	–	> 80

<sup>Ⓢ</sup> Tolerance range for optical and electrical data: ±10 %.

<sup>Ⓢ</sup> If mounted with M4 screws and plastic washers.

<sup>Ⓢ</sup> Integrated measurement over the whole module.

<sup>Ⓢ</sup> HE ... high efficiency, HO ... high output.

## 1. Standards

IEC 62031  
IEC 62471  
IEC 62778  
IEC 61547

### 1.1 Photometric code

Key for photometric code, e. g. 830 / 359

1 <sup>st</sup> digit	2 <sup>nd</sup> + 3 <sup>rd</sup> digit	4 <sup>th</sup> digit	5 <sup>th</sup> digit	6 <sup>th</sup> digit	
Code CRI	Colour temperature in Kelvin x 100	McAdam initial	McAdam after 25% of the life-time (max.6000h)	Luminous flux after 25% of the life-time (max.6000h)	
7 70 – 79				Code	Luminous flux
8 80 – 89				7	≥ 70 %
9 ≥90				8	≥ 80 %
				9	≥ 90 %

### 1.2 Energy classification

Type	Forward current	Energy classification
CLE G3 160mm 3000lm 830 ADV	350 mA	A++
	500 mA	A++
CLE G3 160mm 3000lm 840 ADV	350 mA	A++
	500 mA	A++
CLE G3 190/220mm 1500lm 830 ADV	350 mA	A++
	500 mA	A++
CLE G3 190/220mm 1500lm 840 ADV	350 mA	A++
	500 mA	A++
CLE G3 315mm 4000lm 830 ADV	600 mA	A++
	900 mA	A++
CLE G3 315mm 4000lm 840 ADV	600 mA	A++
	900 mA	A++

## 2. Thermal details

### 2.1 tp point, ambient temperature and life-time

The temperature at tp reference point is crucial for the light output and life-time of a LED product.

For CLE a tp temperature of 65 °C has to be complied in order to achieve an optimum between light output and life-time.

Compliance with the maximum permissible reference temperature at the tc point must be checked under operating conditions in a thermally stable state. The maximum value must be determined under worst-case conditions for the relevant application.

The tc and tp temperature of LED modules from Tridonic are measured at the same reference point.

### 2.2 Storage and humidity

Storage temperature	-30...+80 °C
---------------------	--------------

Operation only in non condensing environment.

Humidity during processing of the module should be between 30 to 70 %.

### 2.3 Thermal design and heat sink

The rated life of LED products depends to a large extent on the temperature. If the permissible temperature limits are exceeded, the life of the CLE will be greatly reduced or the CLE may be destroyed.

### 2.4 Heat sink values

#### CLE G3 160mm 3000lm

ta	tp	Forward current	R <sub>th, hs-a</sub>	Cooling area
25 °C	65 °C	350 mA		self-cooling
35 °C	65 °C	350 mA		self-cooling
45 °C	65 °C	350 mA	2,92 K/W	229 cm <sup>2</sup>
25 °C	65 °C	500 mA	3,79 K/W	176 cm <sup>2</sup>
35 °C	65 °C	500 mA	2,84 K/W	234 cm <sup>2</sup>
45 °C	65 °C	500 mA	1,90 K/W	352 cm <sup>2</sup>

#### CLE G3 190/220mm 1500lm

ta	tp	Forward current	R <sub>th, hs-a</sub>	Cooling area
25 °C	65 °C	350 mA		self-cooling
35 °C	65 °C	350 mA		self-cooling
45 °C	65 °C	350 mA		self-cooling
25 °C	65 °C	500 mA		self-cooling
35 °C	65 °C	500 mA		self-cooling
45 °C	65 °C	500 mA		self-cooling

#### CLE G3 315mm 4000lm

ta	tp	Forward current	R <sub>th, hs-a</sub>	Cooling area
25 °C	65 °C	350 mA		self-cooling
35 °C	65 °C	350 mA		self-cooling
45 °C	65 °C	350 mA		self-cooling
25 °C	65 °C	500 mA		self-cooling
35 °C	65 °C	500 mA		self-cooling
45 °C	65 °C	500 mA		self-cooling

### Notes

The actual cooling can differ because of the material, the structural shape, outside influences and the installation situation. A thermal connection between CLE G3 and heat sink with heat-conducting paste or heat conducting adhesive film is absolutely necessary.

Additionally the CLE G3 has to be fixed on the heat sink with M3 screws to optimise the thermal connection.

Use of thermal interface material with thermal conductivity of  $\lambda > 1$  W/mK and layer thickness of interface material with max. 50  $\mu$ m or a similar interface material where the quotient of layer thickness and thermal conductivity  $b < 50$   $\mu$ mmK/W.

### 3. Installation / wiring

#### 3.1 Electrical supply/choice of LED Driver

CLE from Tridonic are not protected against overvoltages, overcurrents, overloads or short-circuit currents. Safe and reliable operation can only be guaranteed in conjunction with a LED Driver which complies with the relevant standards.

If a LED Driver other than from Tridonic is used, it must provide the following protection:

- Short-circuit protection
- Overload protection
- Overtemperature protection

**!** CLE must be supplied by a constant current LED Driver. Operation with a constant voltage LED Driver will lead to an irreversible damage of the module.

Wrong polarity can damage the CLE.

With parallel wiring tolerance-related differences in output are possible (thermal stress of the module) and can cause differences in brightness. If one module fails, the remaining modules may be overloaded.

CLE have to be operated with a SELV LED Drive.

**!** CLE are basic isolated up to 60 V SELV against ground and can be mounted directly on earthed metal parts of the luminaire. If the max. output voltage of the LED Driver (also against earth) is above 60 V SELV, an additional isolation between LED module and heat sink is required (for example by isolated thermal pads) or by a suitable luminaire construction. At voltages > 60 V an additional protection against direct touch (test finger) to the light emitting side of the module has to be guaranteed. This is typically achieved by means of a non removable light distributor over the module.

#### 3.2 Wiring

CLE G3 160mm

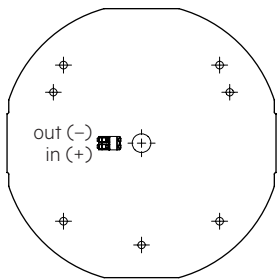

CLE G3 190/220/315mm

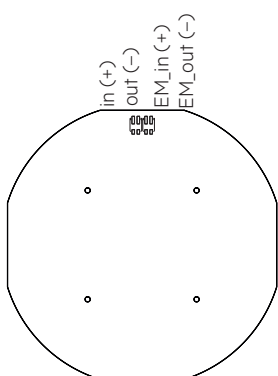

#### Wiring example

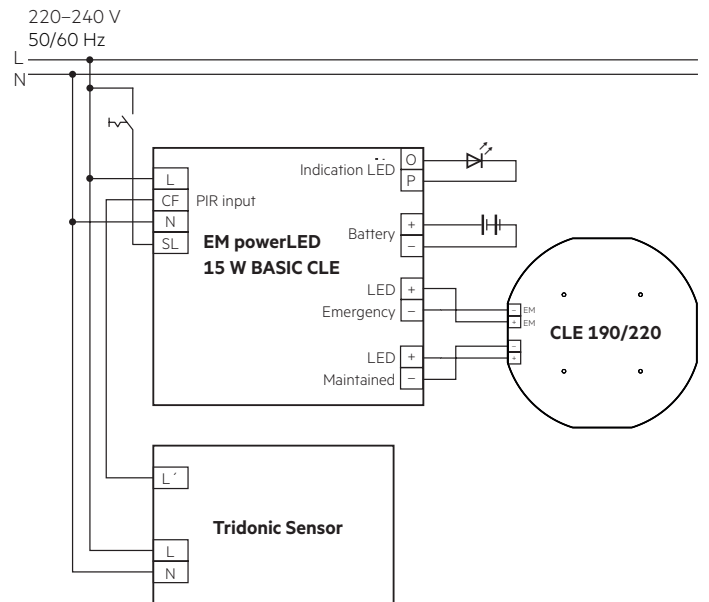
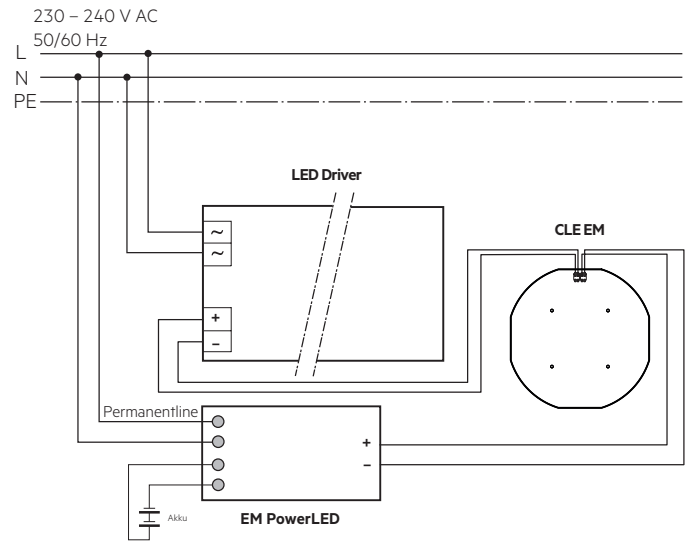

#### 3.3 Wiring type and cross section

The wiring can be solid cable with a cross section of 0.2 to 0.75 mm<sup>2</sup>. For the push-wire connection you have to strip the insulation (7–9 mm). Loosen wire through twisting and pulling.

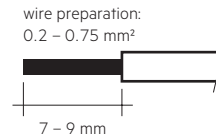

Press down the “push button” and remove the cable from front.

#### 3.4 Mounting instruction

**!** None of the components of the CLE (substrate, LED, electronic components etc.) may be exposed to tensile or compressive stresses.

Max. torque for fixing: 0.5Nm.

The LED modules are mounted with 4 screws per module. In order not to damage the modules only rounded head screws and an additional plastic flat washer should be used.



Chemical substance may harm the LED module. Chemical reactions could lead to colour shift, reduced luminous flux or a total failure of the module caused by corrosion of electrical connections.

Materials which are used in LED applications (e.g. sealings, adhesives) must not produce dissolver gas. They must not be condensation curing based, acetate curing based or contain sulfur, chlorine or phthalate. Avoid corrosive atmosphere during usage and storage.

### 3.5 EOS/ESD safety guidelines



The device / module contains components that are sensitive to electrostatic discharge and may only be installed in the factory and on site if appropriate EOS/ESD protection measures have been taken. No special measures need be taken for devices/modules with enclosed casings (contact with the pc board not possible), just normal installation practice. Please note the requirements set out in the document EOS / ESD guidelines (Guideline\_EOS\_ESD.pdf) at: <http://www.tridonic.com/esd-protection>

## 4. Life-time

### 4.1 Life-time, lumen maintenance and failure rate

The light output of an LED Module decreases over the life-time, this is characterized with the L value.

L70 means that the LED module will give 70 % of its initial luminous flux. This value is always related to the number of operation hours and therefore defines the life-time of an LED module.

As the L value is a statistical value and the lumen maintenance may vary over the delivered LED modules.

The B value defines the amount of modules which are below the specific L value, e.g. L70B10 means 10 % of the LED modules are below 70 % of the initial luminous flux, respectively 90 % will be above 70 % of the initial value. In addition the percentage of failed modules (fatal failure) is characterized by the C value.

The F value is the combination of the B and C value. That means for F degradation and complete failures are considered, e.g. L70F10 means 10 % of the LED modules may fail or be below 70 % of the initial luminous flux.

### 4.2 Lumen maintenance

Life-time declarations are informative and represent no warranty claim.

#### CLE G3 160mm

Forward current	tp temperature	L90 / F10	L90 / F50	L80 / F10	L80 / F50	L70 / F10	L70 / F50
350 mA	45 °C	35,000 h	49,000 h	>50,000 h	>50,000 h	>50,000 h	>50,000 h
350 mA	55 °C	44,000 h	>50,000 h	>50,000 h	>50,000 h	>50,000 h	>50,000 h
350 mA	65 °C	>50,000 h	>50,000 h	>50,000 h	>50,000 h	>50,000 h	>50,000 h
500 mA	45 °C	42,000 h	>50,000 h	>50,000 h	>50,000 h	>50,000 h	>50,000 h
500 mA	55 °C	49,000 h	>50,000 h	>50,000 h	>50,000 h	>50,000 h	>50,000 h
500 mA	65 °C	>50,000 h	>50,000 h	>50,000 h	>50,000 h	>50,000 h	>50,000 h

#### CLE G3 190/220mm

Forward current	tp temperature	L90 / F10	L90 / F50	L80 / F10	L80 / F50	L70 / F10	L70 / F50
350 mA	45 °C	37,000 h	49,000 h	>50,000 h	>50,000 h	>50,000 h	>50,000 h
350 mA	55 °C	46,000 h	>50,000 h	>50,000 h	>50,000 h	>50,000 h	>50,000 h
350 mA	65 °C	>50,000 h	>50,000 h	>50,000 h	>50,000 h	>50,000 h	>50,000 h
500 mA	45 °C	38,000 h	49,000 h	>50,000 h	>50,000 h	>50,000 h	>50,000 h
500 mA	55 °C	47,000 h	>50,000 h	>50,000 h	>50,000 h	>50,000 h	>50,000 h
500 mA	65 °C	>50,000 h	>50,000 h	>50,000 h	>50,000 h	>50,000 h	>50,000 h

#### CLE G3 315mm

Forward current	tp temperature	L90 / F10	L90 / F50	L80 / F10	L80 / F50	L70 / F10	L70 / F50
600 mA	45 °C	35,000 h	49,000 h	>50,000 h	>50,000 h	>50,000 h	>50,000 h
600 mA	55 °C	45,000 h	>50,000 h	>50,000 h	>50,000 h	>50,000 h	>50,000 h
600 mA	65 °C	>50,000 h	>50,000 h	>50,000 h	>50,000 h	>50,000 h	>50,000 h
900 mA	45 °C	38,000 h	49,000 h	>50,000 h	>50,000 h	>50,000 h	>50,000 h
900 mA	55 °C	47,000 h	>50,000 h	>50,000 h	>50,000 h	>50,000 h	>50,000 h
900 mA	65 °C	>50,000 h	>50,000 h	>50,000 h	>50,000 h	>50,000 h	>50,000 h



## 5. Electrical values

### 5.1 Typ. forward voltage vs. forward current

CLE G3 160mm

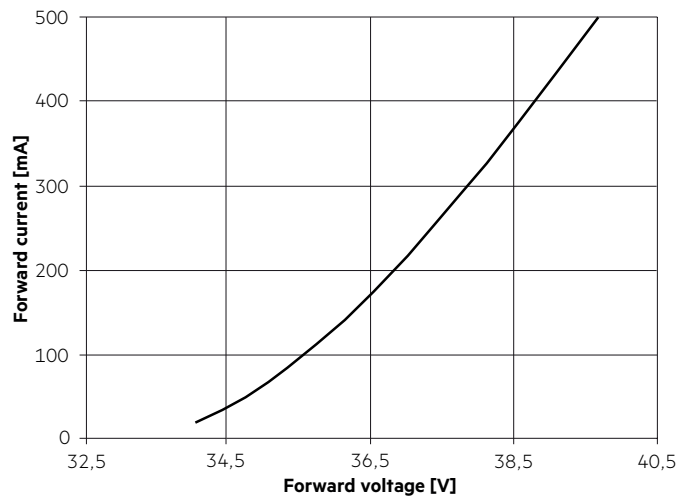

CLE G3 190/220mm

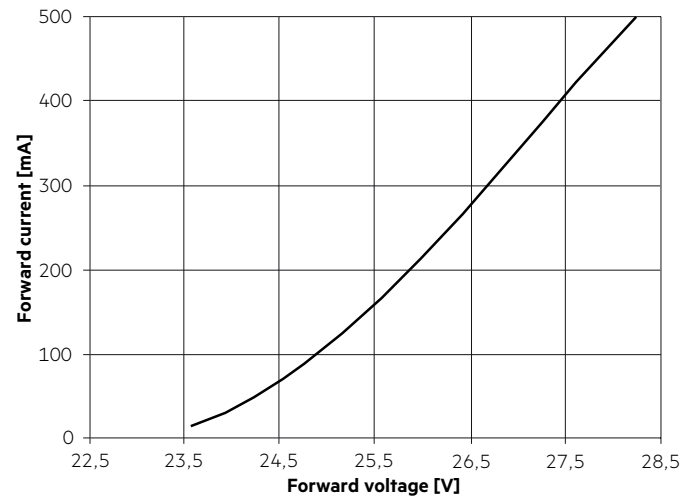

CLE G3 315mm

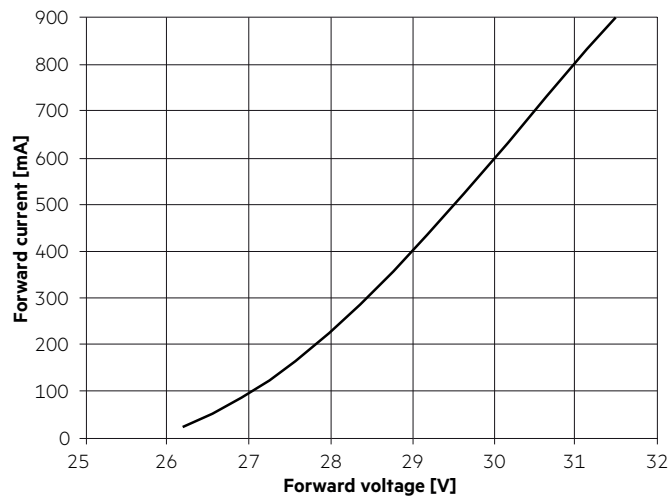

### 5.2 Forward voltage vs. tp temperature

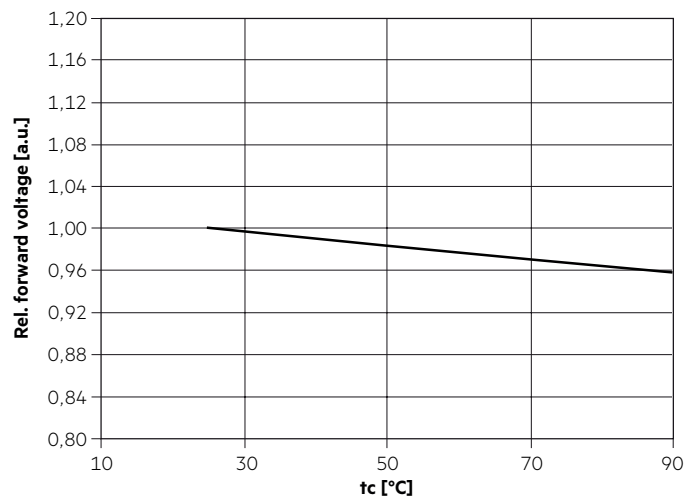

The diagrams based on statistic values. The real values can be different.

## 6. Photometric characteristics

### 6.1 Coordinates and tolerances according to CIE 1931

The specified colour coordinates are measured integral by a current impulse with Irated of the module and a duration of 100 ms.

The ambient temperature of the measurement is  $t_a = 25^\circ\text{C}$ .

The measurement tolerance of the colour coordinates are  $\pm 0.01$ .

#### 3,000 K

	x0	y0
Centre	0.4338	0.4030

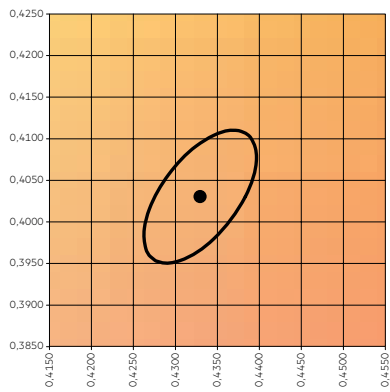

— MacAdam Ellipse: 3SDCM

#### 4,000 K

	x0	y0
Centre	0.3818	0.3797

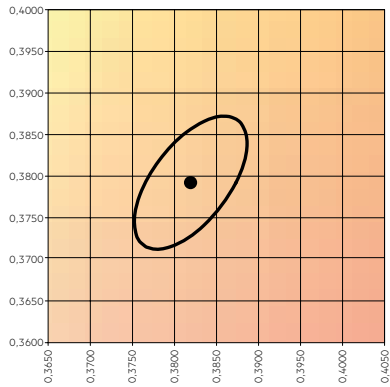

— MacAdam Ellipse: 3SDCM

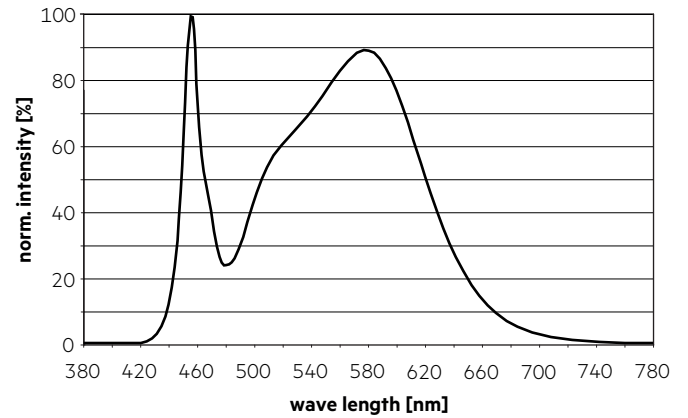
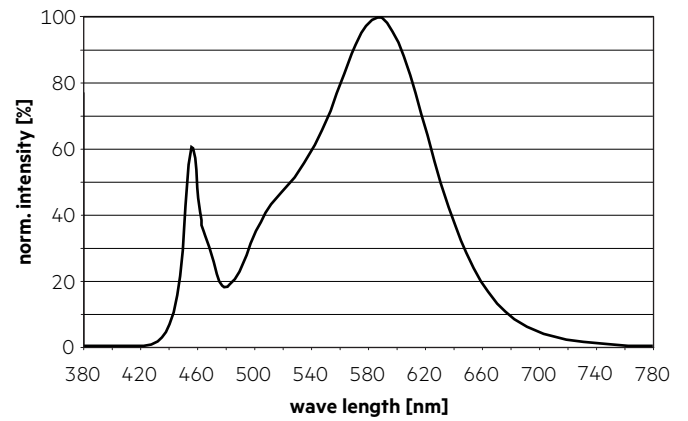

### 6.2 Light distribution

The optical design of the CLE product line ensures optimum homogeneity for the light distribution.

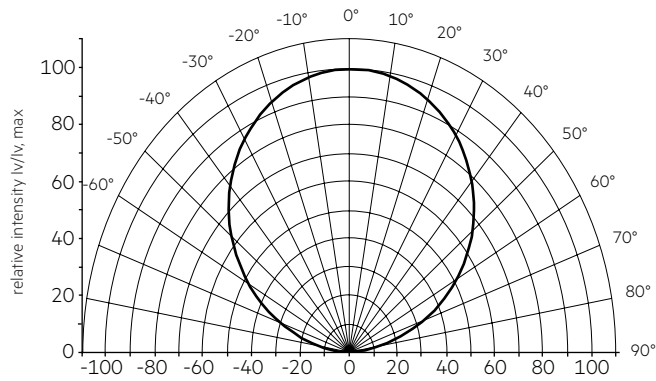

The colour temperature is measured over the complete module. The single LED light points can be outside of 3SDCM.

To ensure an ideal mixture of colours and a homogenous light distribution a suitable optic (e. g. PMMA diffuser) and a sufficient spacing between module and optic (typ. 5 cm) should be used.

3D-Data, photometric data and Design-in guide available on request or go to [www.tridonic.com](http://www.tridonic.com)

### 6.3 Relative luminous flux vs. tc temperature

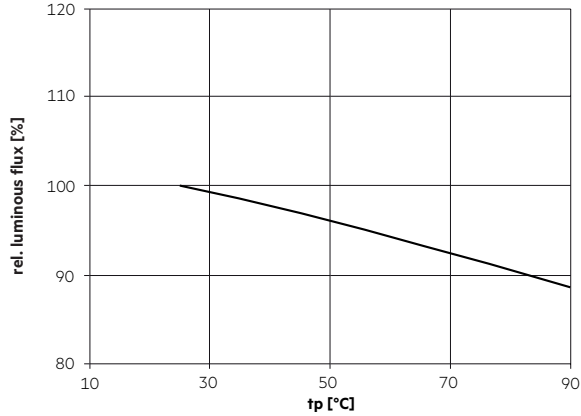

### 6.4 Relative luminous flux vs. operating current

CLE G3 160/190/220mm

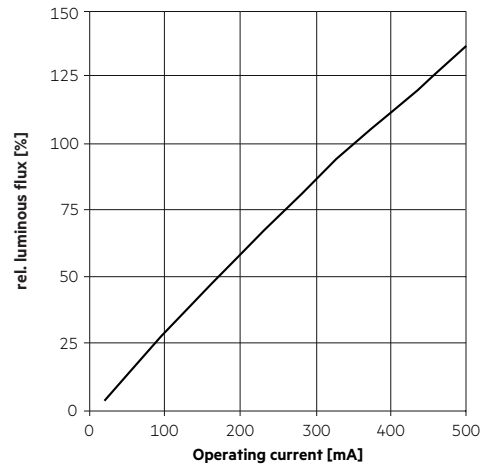

CLE G3 315mm

