

### Driver LC 15/20/25W 350/500/700/600mA fixC C SNC

ESSENCE series

#### Product description

- Fixed output built-in LED Driver
- Constant current LED Driver
- Output current 350, 500, 700 or 600 mA
- Max. output power 15, 20 or 25 W
- Nominal life-time up to 50,000 h
- KC certificate for LC 15W 350mA fixC C SNC, LC 20W 500mA fixC C SNC and LC 20W 700mA fixC C SNC
- For luminaires of protection class I and protection class II
- Temperature protection as per EN 61347-2-13 C5e
- 5-year guarantee



#### Properties

- Casing: polycarbonat, white
- Type of protection IP20

#### Functions

- Overtemperature protection
- Overload protection
- Short-circuit protection
- No-load protection



**Standards**, page 3

**Wiring diagrams and installation examples**, page 4



IP20 SELV RoHS

### Driver LC 15/20/25W 350/500/700/600mA fixC C SNC

ESSENCE series

#### Technical data

Rated supply voltage	220 – 240 V
AC voltage range	198 – 264 V
Mains frequency	50 / 60 Hz
Oversvoltage protection	320 V AC, 1 h
THD (at 230 V, 50 Hz, full load)	< 20 %
Output current tolerance <sup>®</sup>	± 75 %
Typ. current ripple (at 230 V, 50 Hz, full load)	± 30 %
Turn on time (at 230 V, 50 Hz, full load)	≤ 0.5 s
Turn off time (at 230 V, 50 Hz, full load)	≤ 0.5 s
Hold on time at power failure (output)	0 s
Ambient temperature $t_a$	-20 ... +50 °C
Ambient temperature $t_a$ (at life-time 50,000 h)	40 °C
Storage temperature $t_s$	-40 ... +80 °C
Dimensions L x W x H	93 x 58 x 26.2 mm

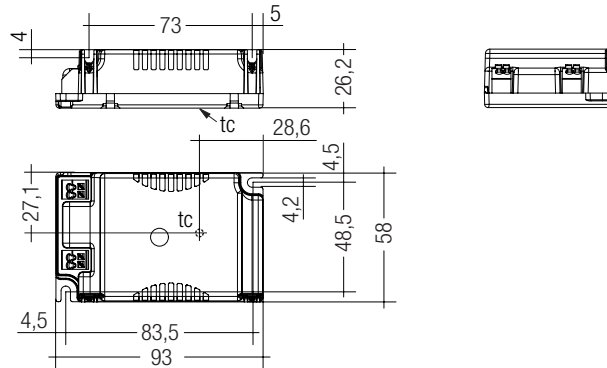

LC 15/20W 350/500/700mA fixC C SNC

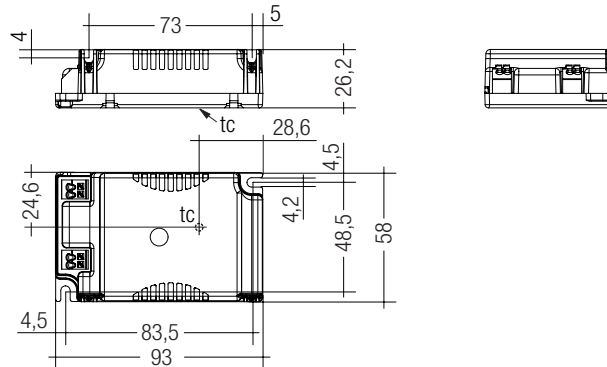

LC 25W 600mA fixC C SNC

#### Ordering data

Type <sup>®</sup>	Article number	Packaging, carton	Packaging, low volume	Packaging, high volume	Weight per pc.
LC 15W 350mA fixC C SNC	87500565	20 pc(s).	280 pc(s).	3,360 pc(s).	0.075 kg
LC 20W 500mA fixC C SNC	87500566	20 pc(s).	280 pc(s).	3,360 pc(s).	0.075 kg
LC 20W 700mA fixC C SNC	87500567	20 pc(s).	280 pc(s).	3,360 pc(s).	0.075 kg
LC 25W 600mA fixC C SNC	87500575	20 pc(s).	280 pc(s).	3,360 pc(s).	0.079 kg

#### Specific technical data

Type	Output current <sup>®</sup>	Input current (at 230 V, 50 Hz, full load)	Max. input power	Typ. power consumption (at 230 V, 50 Hz, full load)	Output power range	Power factor at full load <sup>®</sup>	Efficiency at full load <sup>®</sup>	Power factor at min. load <sup>®</sup>	Efficiency at min. load <sup>®</sup>	Min. forward voltage	Max. forward voltage	Max. output voltage	Max. output peak current at full load <sup>®</sup>	Max. output peak current at min. load <sup>®</sup>	Max. casing temperature $t_c$
LC 15W 350mA fixC C SNC	350 mA	0.083 A	18.0 W	17.0 W	10.5 – 15.0 W	0.92C	87.5 %	0.87C	86.5 %	30 V	43.0 V	56 V	490 mA	560 mA	70 °C
LC 20W 500mA fixC C SNC	500 mA	0.112 A	25.0 W	22.5 W	15.0 – 21.5 W	0.95	87.5 %	0.92C	87.0 %	30 V	43.0 V	56 V	700 mA	800 mA	75 °C
LC 20W 700mA fixC C SNC	700 mA	0.107 A	24.0 W	23.0 W	14.0 – 20.0 W	0.94C	86.0 %	0.90C	85.0 %	20 V	28.5 V	40 V	980 mA	1,120 mA	75 °C
LC 25W 600mA fixC C SNC	600 mA	0.134 A	30.0 W	28.0 W	18.0 – 26.0 W	0.95	88.5 %	0.91C	87.5 %	30 V	43.0 V	56 V	840 mA	960 mA	85 °C

<sup>®</sup> Test result at 230 V, 50 Hz.

<sup>®</sup> The trend between min. and full load is linear.

<sup>®</sup> Output current is mean value.

### Standards

EN 55015  
EN 61000-3-2  
EN 61000-3-3  
EN 61347-1  
EN 61347-2-13  
EN 61547

### Overload protection

If the output voltage range is exceeded the LED Driver will protect itself and LED may flicker. After elimination of the overload, the nominal operation is restored automatically.

### Overtemperature protection

The LED Driver is protected against temporary thermal overheating. If the temperature limit is exceeded, the output current is reduced to limit  $t_c$  at a certain level.

The temperature protection is activated typically at 10 °C above  $t_c$  max.

### Short-circuit behaviour

In case of a short circuit on the secondary side (LED) the LED Driver switches into hic-cup mode. After elimination of the short-circuit fault the LED Driver will recover automatically.

### No-load operation

The LED Driver works in burst working mode to provide a constant output voltage regulation which allows the application to be able to work safely when LED string opens due to a failure.

### Installation instructions

The LED module and all contact points within the wiring must be sufficiently insulated against 3 kV surge voltage.

Air and creepage distance must be maintained.

### Replace LED module

1. Mains off
2. Remove LED module
3. Wait for 10 seconds
4. Connect LED module again

Hot plug-in or secondary switching of LEDs is not permitted and may cause a very high current to the LEDs.

### Expected life-time

Type	$t_a$	40 °C	50 °C	60 °C
<b>LC 15W 350mA fixC C SNC</b>	$t_c$	60 °C	70 °C	x
	Life-time	50,000 h	30,000 h	x
<b>LC 20W 500/700mA fixC C SNC</b>	$t_c$	65 °C	75 °C	x
	Life-time	50,000 h	30,000 h	x
<b>LC 25W 600mA fixC C SNC</b>	$t_c$	75 °C	85 °C	x
	Life-time	50,000 h	30,000 h	x

The LED Drivers are designed for a life-time stated above under reference conditions and with a failure probability of less than 10 %.

Life-time declarations are informative and represent no warranty claim.

### Maximum loading of automatic circuit breakers

Automatic circuit breaker type	C10	C13	C16	C20	B10	B13	B16	B20	Inrush current	
Installation $\varnothing$	1,5 mm <sup>2</sup>	1,5 mm <sup>2</sup>	1,5 mm <sup>2</sup>	2,5 mm <sup>2</sup>	1,5 mm <sup>2</sup>	1,5 mm <sup>2</sup>	1,5 mm <sup>2</sup>	2,5 mm <sup>2</sup>	$I_{max}$	Time
<b>LC 15W 350mA fixC C SNC</b>	105	140	170	215	90	115	145	175	8 A	80 $\mu$ s
<b>LC 20W 500mA fixC C SNC</b>	75	95	120	150	65	90	110	130	8 A	80 $\mu$ s
<b>LC 20W 700mA fixC C SNC</b>	80	100	125	160	65	90	110	130	8 A	80 $\mu$ s
<b>LC 25W 600mA fixC C SNC</b>	60	80	100	125	55	70	90	110	8 A	80 $\mu$ s

### Glow-wire test

according to EN 61347-1 with increased temperature of 850 °C passed.

### Mounting of device

Max. torque for fixing: 0.5 Nm/M4

### Storage conditions

Humidity: 5 % up to max. 85 %, not condensed (max. 56 days/year at 85 %)

Storage temperature: -40 °C up to max. +80 °C

The devices have to be within the specified temperature range ( $t_a$ ) before they can be operated.

Harmonic distortion in the mains supply (at 230 V / 50 Hz and full load) in %

	THD	3.	5.	7.	9.	11.
LC 15W 350mA fixC C SNC	20	10	3	3	3	2
LC 20W 500mA fixC C SNC	20	11	3	2	2	2
LC 20W 700mA fixC C SNC	20	10	2	2	2	2
LC 25W 600mA fixC C SNC	20	12	3	2	2	2

### Wiring diagram

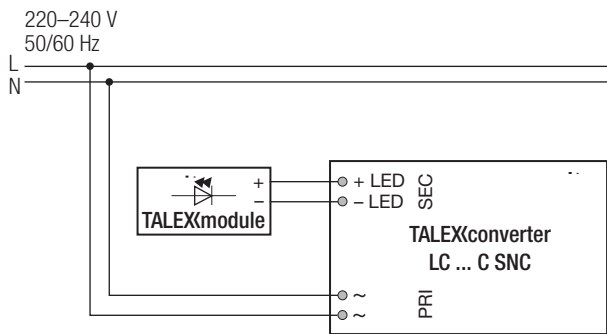

### Isolation and electric strength testing of luminaires

Electronic devices can be damaged by high voltage. This has to be considered during the routine testing of the luminaires in production.

According to IEC 60598-1 Annex Q (informative only!) or ENEC 303-Annex A, each luminaire should be submitted to an isolation test with 500 V<sub>DC</sub> for 1 second. This test voltage should be connected between the interconnected phase and neutral terminals and the earth terminal. The isolation resistance must be at least 2 MΩ.

As an alternative, IEC 60598-1 Annex Q describes a test of the electrical strength with 1500 V<sub>AC</sub> (or 1.414 x 1500 V<sub>DC</sub>). To avoid damage to the electronic devices this test must not be conducted.

### Additional information

Additional technical information at [www.tridonic.com](http://www.tridonic.com) → Technical Data

Guarantee conditions at [www.tridonic.com](http://www.tridonic.com) → Services

Life-time declarations are informative and represent no warranty claim. No warranty if device was opened.

### Wiring type and cross section

The wiring can be done with a cross section of 0.5 – 1.5 mm<sup>2</sup>.

Strip 8.5 – 9.5 mm of insulation from the cables to ensure perfect operation of the push-wire terminals.

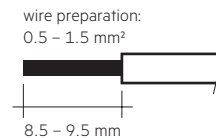

### Wiring guidelines

- All connections must be kept as short as possible to ensure good EMI behaviour.
- Mains leads should be kept apart from LED Driver and other leads (ideally 5 – 10 cm distance)
- Max. length of output wires is 2 m.
- Secondary switching is not permitted.
- Incorrect wiring can damage LED modules.
- The wiring must be protected against short circuits to earth (sharp edged metal parts, metal cable clips, louver, etc.).

### Release of the wiring

Press down the “push button” and remove the cable from front.

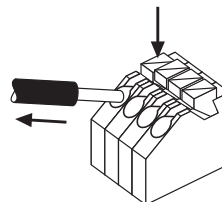

**Diagrams LC 15W 350mA fixC C SNC**

Efficiency vs load

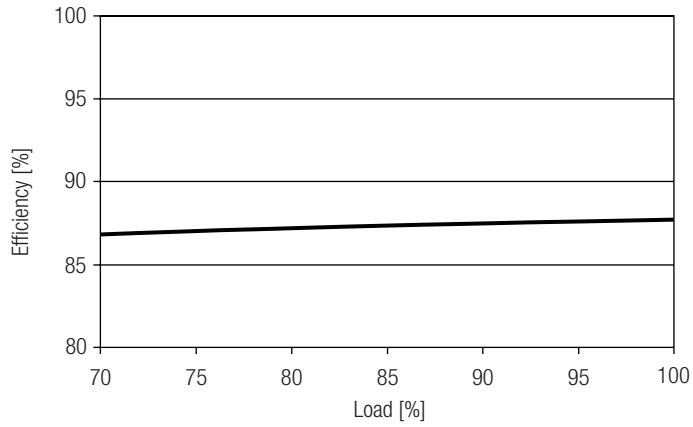

Power factor vs load

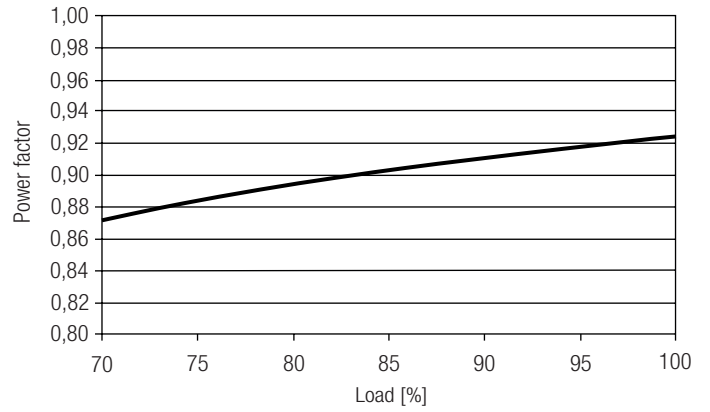

Input power vs load

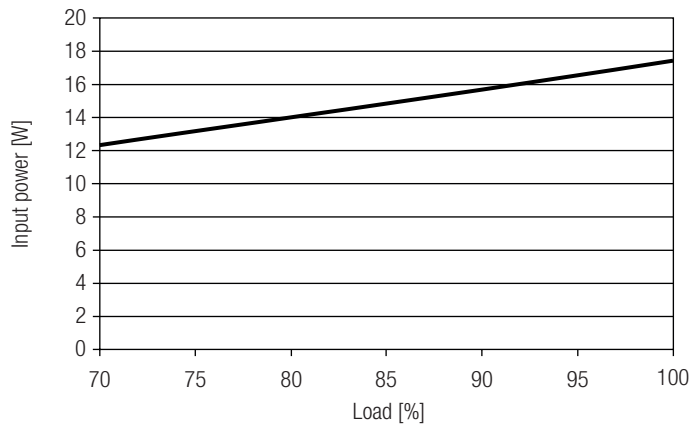

Input current vs load

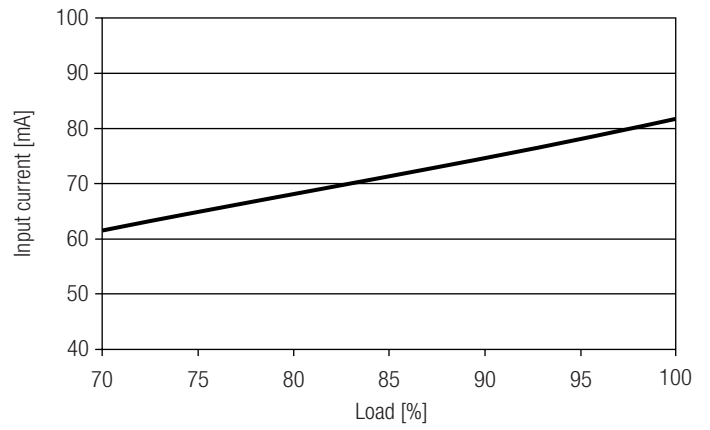

THD vs load

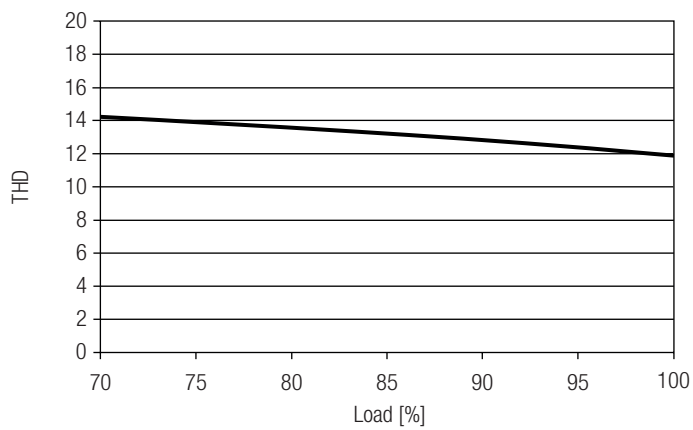

**Diagrams LC 20W 500mA fixC C SNC**

Efficiency vs load

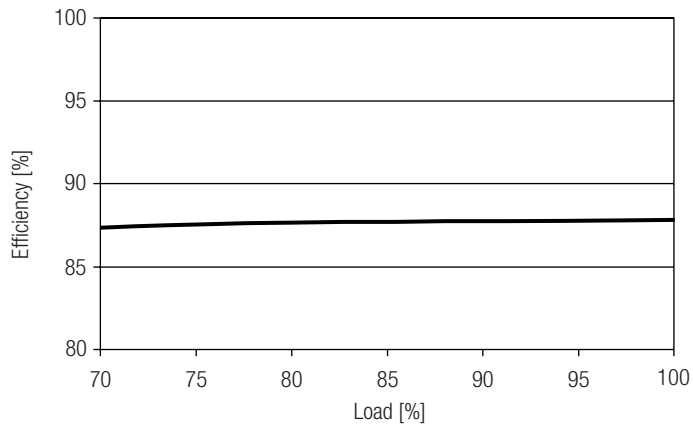

Power factor vs load

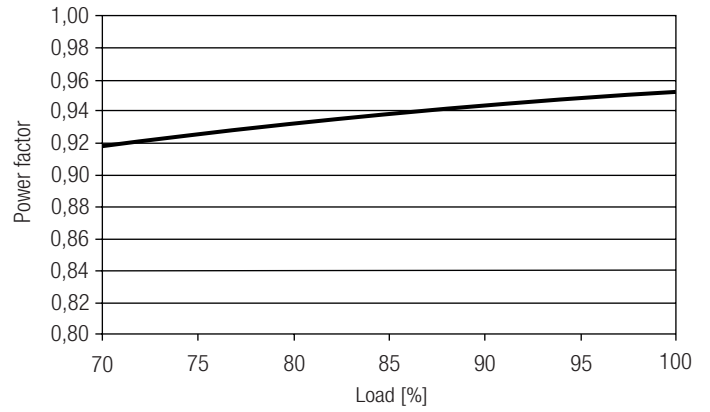

Input power vs load

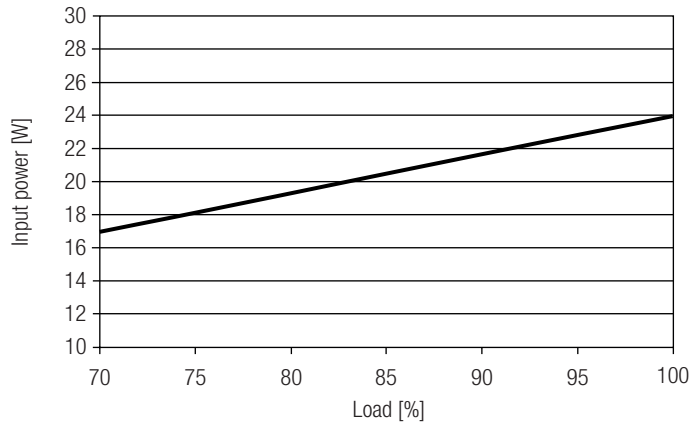

Input current vs load

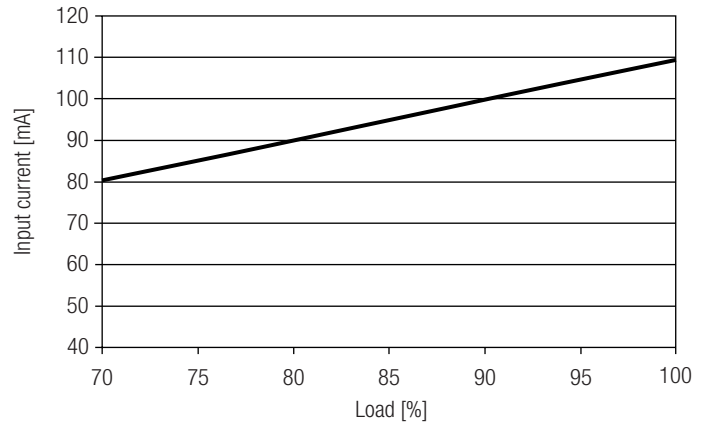

THD vs load

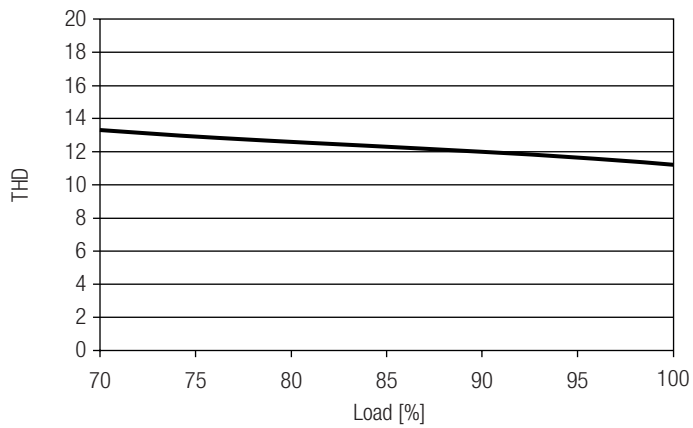

**Diagrams LC 20W 700mA fixC C SNC**

Efficiency vs load

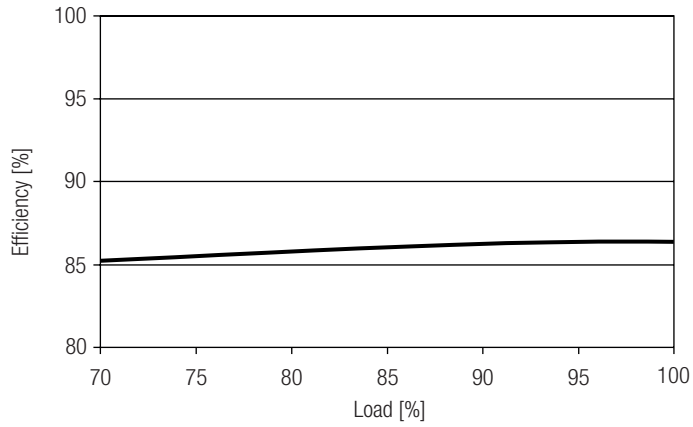

Power factor vs load

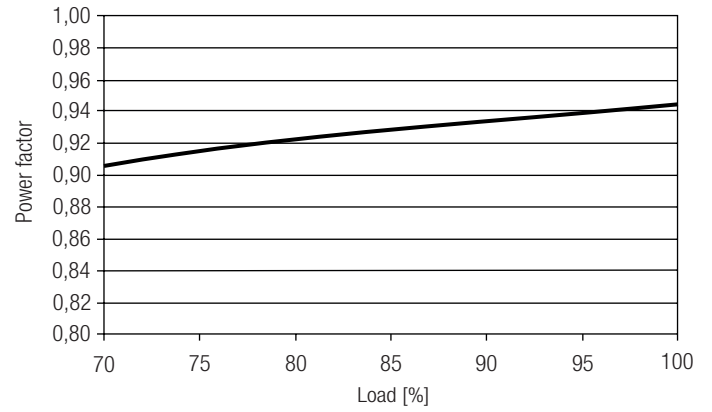

Input power vs load

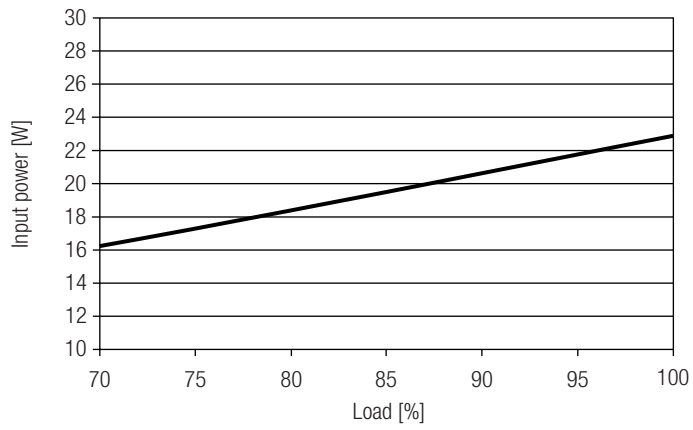

Input current vs load

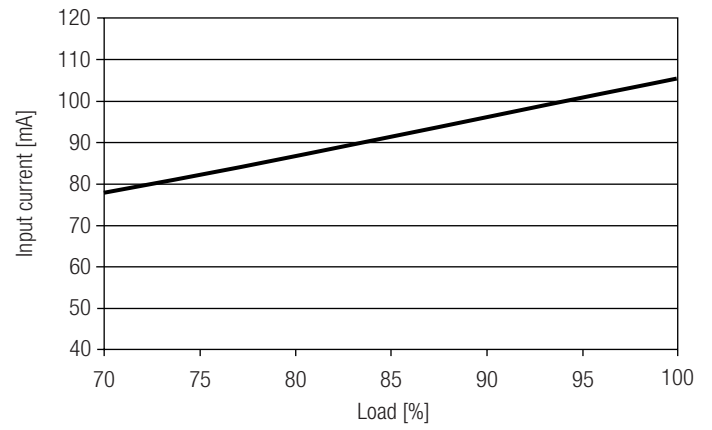

THD vs load

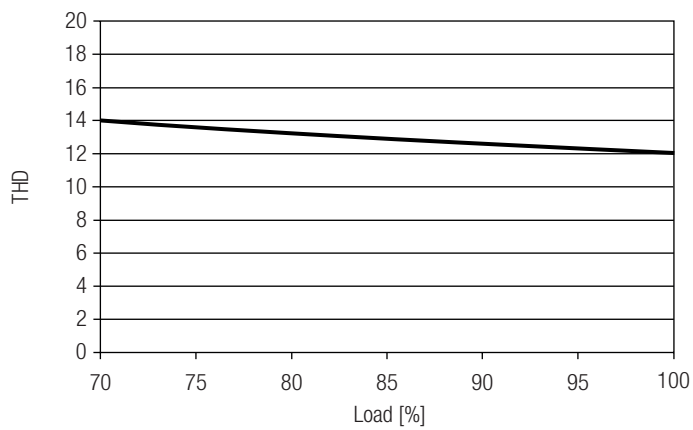

**Diagrams LC 25W 600mA fixC C SNC**

Efficiency vs load

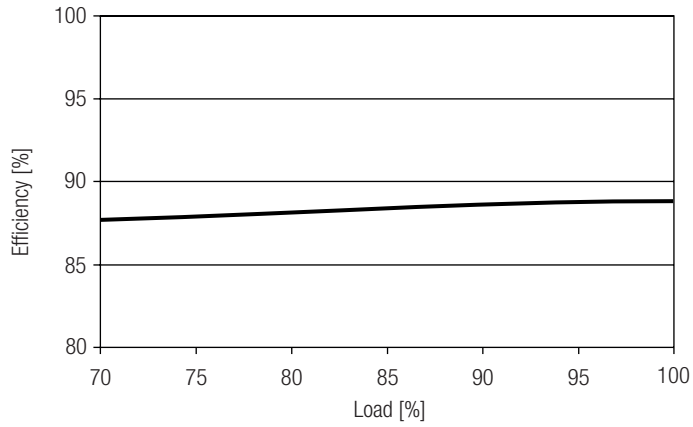

Power factor vs load

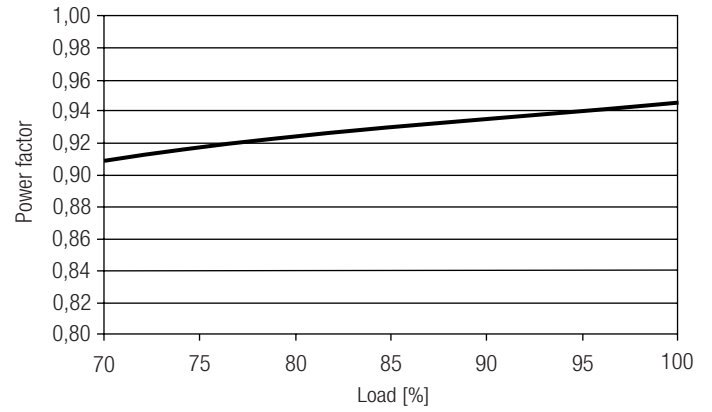

Input power vs load

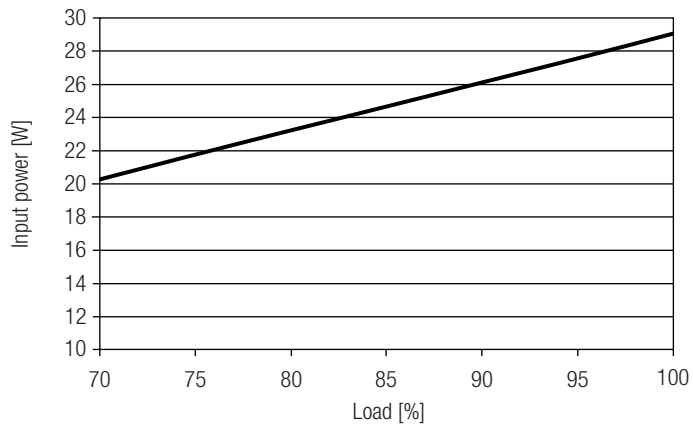

Input current vs load

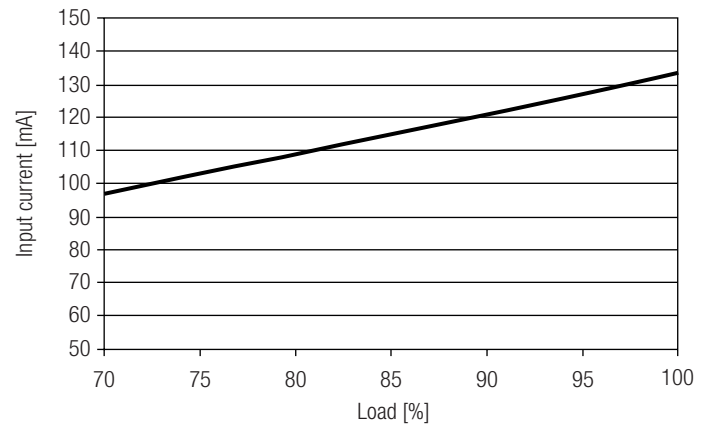

THD vs load

