

basicDIM Wireless

Wireless module for basicDIM

Product description

- Wireless controllable with a Android / iOS smart device
- No need for an external gateway device
- Forms automatically a wireless communication network with up to 127 nodes
- Small form factor for luminaire installation
- Configurable analog / digital output
- Analog output: 0 – 10 V / 1 – 10 V sinking / sourcing
- Digital output: Standalone DALI (compatible)
- Easily implemented RGB and colour temperature controls
- Controllable switched mains output
- Device firmware can be updated over-the-air
- 5-year guarantee



Standards, page 4



basicDIM Wireless

Wireless module for basicDIM

Technical data

Rated supply voltage	220 - 240 V
Mains frequency	50 / 60 Hz
Radio transceiver operating frequencies	2.4 - 2.483 GHz
Max. output power radio transceiver	+4 dBm
Bus voltage DC DALI output	12 V
Shortcircuit current DALI output	7 mA
Max. DALI wiring length	1 m at 1 mm ² cross section
Operating temperature	-20 ... +50 °C
tc point	70 °C
Storage temperature	-25 ... +75 °C
Dimensions LxWxH	56.5 x 35.8 x 22.3 mm
Type of protection	IP20

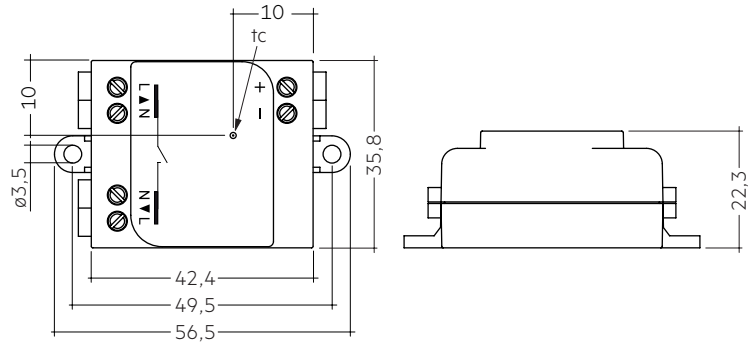

Ordering data

Type	Article number	Packaging, carton	Weight per pc.
basicDIM Wireless	28002212	100 pc(s).	0.048 kg

Product description

- Battery powered, wireless wall switch
- Controls all types of basicDIM wireless devices
- 4 scenes
- Dim up / down
- Colour temperature control
- 5-year guarantee



Ordering data

Type	Article number	Packaging carton	Weight per pc.
basicDIM Wireless User Interface	28002213	50 pc(s).	0.078 kg

1. Standards

EN 55015
 EN 61000-3-2
 EN 61000-3-3
 EN 61347-1
 EN 61347-2-11
 EN 61547

1.1 Glow wire test

according to EN 61347-2-11 with increased temperature of 850 °C passed.

2. Common

2.1 Description

basicDIM Wireless is a wireless control unit for dimmable LED Drivers with 0 – 10 V, 1 – 10 V or DALI dimming interface.

The device is intended to be integrated into a luminaire. The control output can be configured either as analog 0 – 10 V (and 1 – 10 V) or digital Standalone DALI control interface.

When the output is configured as Standalone DALI, basicDIM Wireless acts both as a controller and as a power supply making it possible to connect directly to an LED Driver with DALI interface without the need for an external DALI power supply. This so called Standalone DALI makes it possible to implement multi-channel luminaires with adjustable colour (RGB) or colour temperature, while keeping the wiring and number of components at their minimum.

basicDIM Wireless does not comply with IEC 60929 and therefore is not designed to be connected to an existing DALI network. The module can be used only in a closed system, i.e. inside a luminaire which does not have an external DALI interface. basicDIM Wireless is controlled wirelessly by a smartphone or tablet with control app.

Devices form automatically a secure wireless mesh network so that a large number of fixtures can be controlled from any point. No external gateway module is needed. basicDIM Wireless can be controlled also from standard on/off wall switches.

2.2 Operation

Tridonic basicDIM Wireless is a wireless control unit for LED Drivers with 0 – 10 V, 1 – 10 V or DALI dimming interface. The device is intended to be integrated into a luminaire. The output can be configured either as analog 0 – 10 V (and 1 – 10 V) or digital Standalone DALI control interface.

When the output is configured as Standalone DALI, basicDIM Wireless acts both as a controller and a power supply making it possible to connect directly to an LED Driver with DALI interface without the need for an external DALI power supply.

For applications where the LED Driver cannot be turned completely off through its control interface, basicDIM Wireless has a controllable switched mains output. This mains output is taken directly from the mains input and routed through a fuse and a solid-state relay.

The control output of basicDIM Wireless is double insulated from the mains voltage. The control output is protected against short circuit.

basicDIM Wireless is controlled wirelessly by a smartphone or a tablet with control app. Multiple devices form automatically a mesh network, which can be controlled from any point. The network communicates directly with the smartphone or tablet. No external gateway device or Wireless LAN network is needed.

basicDIM Wireless has an integrated 2.4 GHz antenna. For optimum RF-performance, a special attention will have to be given when the device is integrated to a luminaire. See chapter 5.4 Placement for further instructions.

The device can be operated also from a regular on/off wall switch. By flicking the switch on and off the user can select different pre-set modes. These modes can affect one or several devices on the network. This way the user does not have to have the smartphone or tablet at hand all the time in order to select the desired settings or modes.

The settings and modes can be configured using the control app. They are automatically stored in the Tridonic cloud service. This way the same settings are available for everyone who is connected to the network.

3. Thermal details and life-time

3.1 Expected life-time

Expected life-time

Type	ta	50 °C
basicDIM Wireless	tc	50 °C
	Life-time	50,000 h

The device is designed for a life-time stated above under reference conditions and with a failure probability of less than 10 %.

4. Interfaces / communication

4.1 Standalone DALI output

By default, the output of basicDIM Wireless is configured as DALI interface. In this mode basicDIM Wireless can be connected to any LED Driver with DALI interface.

The control output of basicDIM Wireless can be configured also as a digital Standalone DALI control interface. With this configuration the module can be connected to an LED Driver with DALI interface. The DALI interface makes it possible, for example, to use multi-channel LED Drivers in applications where colour or colour temperature can be controlled.

basicDIM Wireless is designed to control only one LED Driver, whether it has a 0 – 10 V or DALI control interface. If multiple channels are wanted to be controlled simultaneously, a multi-channel LED Driver with DALI interface, or multiple basicDIM Wireless connected to individual LED Drivers, will have to be used.

The operation of the DALI interface has been divided into two. Basic operation does not require the use of LED Driver short addresses, i.e. it does not require pre-configured LED Drivers. Instead it utilizes broadcast commands “forcing” the LED Driver into a desired state.

This method of control does not support multi-channel systems.

For multi-channel systems, an advanced DALI interface will have to be used. This requires assigning short addresses to the LED Driver as well as configuring these addresses to the basicDIM Wireless firmware. The short addresses are assigned to the LED Driver by using a USB-DALI configuration tool which is usually provided by the LED Driver manufacturer.

The basicDIM Wireless firmware can be configured by using Tridonic Utility application.

LED Drivers with DALI interface can be switched off through DALI commands, so when using the basicDIM Wireless in Standalone DALI configuration, it is recommended to power the LED Driver directly from mains voltage and not through basicDIM Wireless. This way the LED Driver power consumption and inrush current may be ignored when designing a luminaire.

4.2 0 – 10 V output

The output of the basicDIM Wireless can also be configured as analog 0 – 10 V / 1 – 10 V dimming interface.

The analog dimming interface of basicDIM Wireless can sink or source up to 7 mA and is protected against short circuit.

0 – 10 V dimming interface enables only one channel dimming. If several channels are required, for example in RGB solution, multiple basicDIM Wireless modules will have to be used together with multiple LED Drivers with 0 – 10 V dimming interface. The 0 – 10 V output may be used with only one LED Driver and it should never be branched to multiple LED Drivers.

It is important to make sure that the wires of 0 – 10 V control interface are connected in right polarity. For this there are plus and minus signs printed on the top cover of basicDIM Wireless.

basicDIM Wireless has also a switched mains output for powering the connected LED Driver. See chapter 4.3 for more information on this feature.



basicDIM Wireless is not designed according to IEC 60929 and therefore should not be connected to an existing DALI network. The module can be used only in a closed system, i.e. inside a luminaire which does not have an external DALI interface. To make a distinction between regular DALI system and a closed DALI system, term “Standalone DALI” is used in this datasheet.

basicDIM Wireless is designed to control only one LED Driver, whether it has a 0 – 10 V or DALI control interface. If multiple channels are wanted to be controlled simultaneously, a multi-channel LED Driver with DALI interface, or multiple basicDIM Wireless connected to individual LED Drivers, will have to be used.

4.3 Mains output

For applications where the LED Driver cannot be turned completely off through its control interface (e.g. 0 – 10 V and 1 – 10 V), basicDIM Wireless has a controllable switched mains output. This mains output is taken from the mains input and routed through a solid-state relay. Solid-state relay switches only the live wire of mains voltage, while neutral is directly connected between mains input and output. Both the mains input and output are protected with a common 2 A slow blow fuse connected to the live wire.

Do not connect the mains output directly to the LED Driver.

It is strongly recommended to use an external relay to switch the mains supply for the LED Driver.

The max. load of the relay output is 5 W.

See 5.2 wiring diagram with external relay.

5. Installation / wiring

5.1 Wiring diagram DALI (compatible mode)

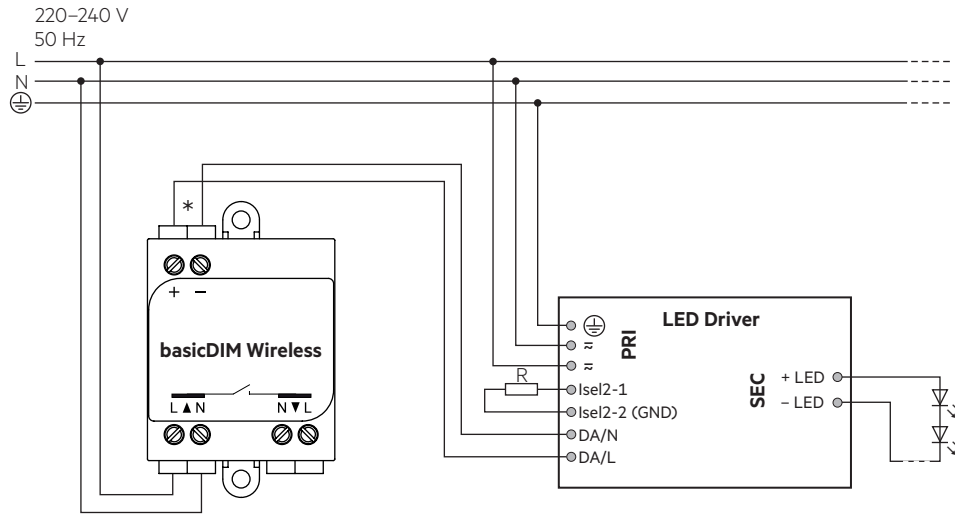

* Max. wiring length 1 m with a cross section of 1 mm².

5.2 Wiring diagram analog dimming (0 - 10 V / 1 - 10 V) with external relay contact

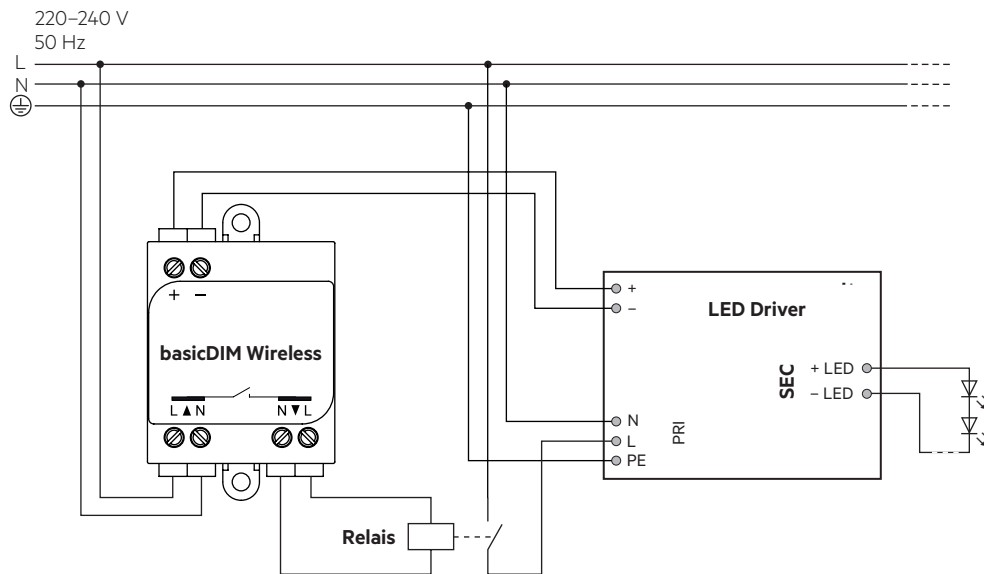

5.3 Wiring diagram as push button module for wireless switching

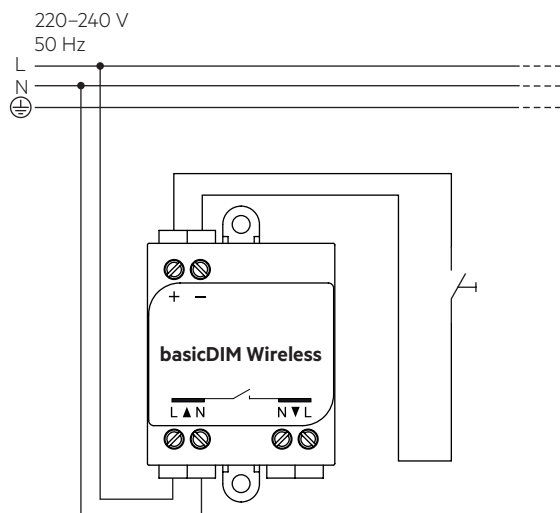

5.4 Wiring diagram as sensor module for wireless switching

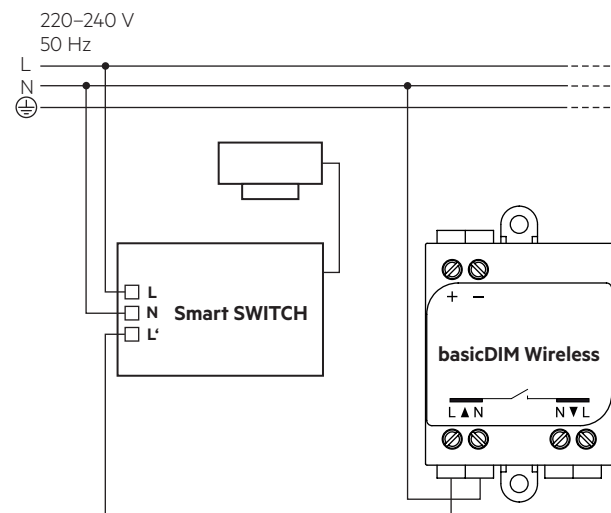

5.3 Wiring type and cross section

The wiring can be in stranded wires with ferrules or solid with a cross section of 0.75–1.5 mm² (14–22 AWG).

Strip 6–7 mm of insulation from the cables to ensure perfect operation of the push-wire terminals.

Use one wire for each terminal connector only.

Use each strain relief channel for one cable only.

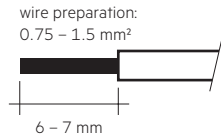

5.4 Placement

basicDIM Wireless has an integrated antenna for easy integration. In order to maximize the range in every direction some design guidelines should be taken into consideration when mounting the device.

The antenna is located on the corner of the enclosure. It is on the bottom side of the internal PCB (Printed Circuit Board) right above the bottom of the device. basicDIM Wireless has some large components on the top side of the PCB, so by placing the antenna on the bottom side the other components have as little impact on the antenna performance as possible.

When the device is mounted on a metal plate (e.g. frame of a luminaire), it may efficiently block the radio frequency signal. In this case, a cut-out underneath the antenna may be needed for the RF signal to exit the structure. The cut-out area should be as large as possible. Also the device should be placed as far away from any vertical metal structures as possible.

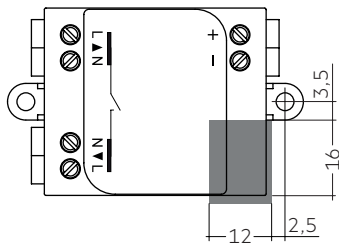

■ Antenna cutout is located on the bottom of the device.



The range of the communication signal is depending on the environment e.g. luminaire, construction of the building, furnitures or humans and needs to be tested and approved in the installation.



To ensure a good radio connection, do not cover the basicDIM Wireless completely with metal!

5.5 Installation note

Max. torque at the clamping screw: 0.5 Nm / M3.

6. Miscellaneous

6.1 Conditions of use and storage

Environmental conditions: 0 % up to max. 80 %, not condensed

Storage temperature: -25 °C up to max. +75 °C

The devices have to be acclimatised to the specified temperature range (ta) before they can be operated.

6.2 Additional information

Additional technical information at www.tridonic.com → Technical Data

Guarantee conditions at www.tridonic.com → Services

Life-time declarations are informative and represent no warranty claim. No warranty if device was opened.