



Driver LC 75W 250–550mA flexC Ip EXC

EXCITE series

Product description

- Built-in constant current LED Driver
- Dimmable via ready2mains™ Gateway
- Dimming range 15 – 100 % (Depending on load.
For details refer to chapter 4.7 Dimming in data sheet.)
- Adjustable output current between 250 and 550 mA
via ready2mains™ Programmer or I-select 2 plug
- Max. output power 75 W
- Up to 94 % efficiency
- For luminaires of protection class I and protection class II
- Nominal life-time up to 100,000 h
- 5-year guarantee



Housing properties

- Low-profile metal casing with white cover
- Type of protection IP20

Interfaces

- ready2mains™ (configuration and dimming via mains)
- Terminal blocks: 0° push terminals

Functions

- Adjustable output current in 1-mA-steps (ready2mains™, I-select 2)
- Dimmable via ready2mains™ interface
- Protective features (overtemperature, short-circuit, overload, no-load, input voltage range)
- Suitable for emergency lighting systems acc. to EN 50172

Benefits

- Application-oriented operating window for maximum compatibility
- Best energy savings due to high efficiency and dimming via ready2mains™
- Flexible configuration via ready2mains™ and I-select 2
- Reliability proven by life-time up to 100,000 h and 5-year guarantee

Typical applications

- For linear/area lighting in office applications



Standards, page 5

IP20 RoHS

Driver LC 75W 250–550mA flexC Ip EXC

EXCITE series

Technical data

| | |
|--|-------------------------|
| Rated supply voltage | 220 – 240 V |
| AC voltage range | 198 – 264 V |
| DC voltage range | 176 – 280 V |
| Mains frequency | 0 / 50 / 60 Hz |
| Overvoltage protection | 320 V AC, 48 h |
| Typ. current (at 230 V, 50 Hz, full load) ^① | 345 mA |
| Typ. current (220 V, 0 Hz, full load, 50 % dimming level) ^② | 178 mA |
| Leakage current (at 230 V, 50 Hz, full load) ^③ | < 250 µA |
| Max. input power | 81 W |
| Typ. efficiency (at 230 V / 50 Hz / full load) ^④ | 94 % |
| λ (at 230 V, 50 Hz, full load) ^⑤ | 0.98 |
| Typ. input current in no-load operation | 23.3 mA |
| Typ. input power in no-load operation | 0.39 W |
| In-rush current (peak / duration) | 577 A / 217 µs |
| THD (at 230 V, 50 Hz, full load) ^⑥ | < 10 % |
| Time to light (at 230 V, 50 Hz, full load) ^⑦ | < 500 ms |
| Time to light (DC mode) | < 500 ms |
| Switchover time (AC/DC) | < 0.2 s |
| Turn off time (at 230 V, 50 Hz, full load) | < 50 ms |
| Output current tolerance ^⑧ | ± 5 % |
| Max. output current peak (non-repetitive) | ≤ output current + 35 % |
| Output LF current ripple (< 120 Hz) | ± 5 % |
| Max. output voltage | 250 V |
| Dimming range ^⑨ | 15 – 100 % |
| Mains surge capability (between L - N) | 1 kV |
| Mains surge capability (between L/N - PE) | 2 kV |
| Surge voltage at output side (against PE) | 2.5 kV |
| Dimensions L x W x H | 280 x 30 x 21 mm |

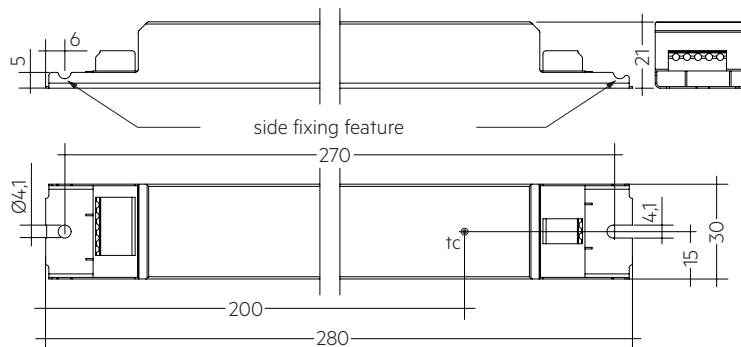

Ordering data

| Type | Article number | Packaging carton | Packaging pallet | Weight per pc. |
|-------------------------------|----------------|------------------|------------------|----------------|
| LC 75W 250-550mA flexC Ip EXC | 28001808 | 10 pc(s). | 960 pc(s). | 0.205 kg |

Specific technical data

| Type | Output current ^⑩ | Min. forward voltage | Max. forward voltage | Max. output power | Typ. power consumption (at 230 V, 50 Hz, full load) | Typ. current consumption (at 230 V, 50 Hz, full load) | Max. casing temperature tc | Ambient temperature ta max. | I-select 2 resistor value ^⑪ |
|-------------------------------|-----------------------------|----------------------|----------------------|-------------------|---|---|----------------------------|-----------------------------|--|
| LC 75W 250-550mA flexC Ip EXC | 250 mA | 80 V | 220,0 V | 55,0 W | 56,3 W | 251 mA | 75 °C | -25 ... +60 °C | open |
| | 275 mA | 80 V | 220,0 V | 60,5 W | 64,5 W | 287 mA | 75 °C | -25 ... +60 °C | 18.18 kΩ |
| | 300 mA | 80 V | 220,0 V | 66,0 W | 70,2 W | 311 mA | 75 °C | -25 ... +60 °C | 16.67 kΩ |
| | 325 mA | 80 V | 220,0 V | 71,5 W | 75,1 W | 332 mA | 75 °C | -25 ... +60 °C | 15.38 kΩ |
| | 350 mA | 80 V | 214,3 V | 75,0 W | 80,4 W | 346 mA | 75 °C | -25 ... +60 °C | 14.29 kΩ |
| | 375 mA | 80 V | 200,0 V | 75,0 W | 80,2 W | 345 mA | 75 °C | -25 ... +60 °C | 13.33 kΩ |
| | 400 mA | 80 V | 187,5 V | 75,0 W | 80,3 W | 345 mA | 75 °C | -25 ... +60 °C | 12.50 kΩ |
| | 425 mA | 80 V | 176,5 V | 75,0 W | 80,2 W | 345 mA | 75 °C | -25 ... +60 °C | 11.76 kΩ |
| | 450 mA | 80 V | 166,7 V | 75,0 W | 80,2 W | 345 mA | 75 °C | -25 ... +60 °C | 11.11 kΩ |
| | 475 mA | 80 V | 157,9 V | 75,0 W | 80,2 W | 345 mA | 75 °C | -25 ... +60 °C | 10.53 kΩ |
| | 500 mA | 80 V | 150,0 V | 75,0 W | 80,0 W | 345 mA | 75 °C | -25 ... +60 °C | 10.00 kΩ |
| | 525 mA | 80 V | 142,9 V | 75,0 W | 80,1 W | 345 mA | 75 °C | -25 ... +60 °C | 9.52 kΩ |
| | 550 mA | 80 V | 136,4 V | 75,0 W | 80,5 W | 345 mA | 75 °C | -25 ... +60 °C | short circuit (0 Ω) |

^⑩ Valid at 100 % dimming level.

^⑪ Depending on the selected output current.

^⑫ The min. achievable dimming level depends on the connected load. For details refer to chapter 4.7 Dimming in data sheet.

^⑬ The table only lists a number of possible operating points but does not cover each single point. The output current can be set within the total value range in 1-mA-steps.

^⑭ Not compatible with I-select (generation 1).

^⑮ Output current is mean value.

Product description

- Ready-for-use resistor to set output current value
- Compatible with LED Driver featuring I-select 2 interface; not compatible with I-select (generation 1)
- Resistor is base isolated
- Resistor power 0.25 W
- Current tolerance $\pm 2\%$ additional to output current tolerance
- Compatible with LED Driver series PRE and EXC

Example of calculation for third party resistors

- $R [k\Omega] = 5 V / I_{out} [mA] \times 1000$
- Resistor value tolerance $\leq 1\%$; resistor power $\geq 0.1 W$; base isolation necessary
- When using a resistor value beyond the specified range, the output current will automatically be set to the minimum value (resistor value too big), respectively to the maximum value (resistor value too small)

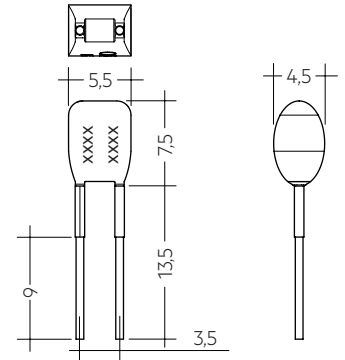
**Ordering data**

| Type | Article number | Colour | Marking | Current | Packaging bag | Weight per pc. |
|--------------------------|----------------|--------|---------|---------|---------------|----------------|
| I-SELECT 2 PLUG 250MA BL | 28001106 | Blue | 0250 mA | 250 mA | 10 pc(s). | 0.001 kg |
| I-SELECT 2 PLUG 275MA BL | 28001107 | Blue | 0275 mA | 275 mA | 10 pc(s). | 0.001 kg |
| I-SELECT 2 PLUG 300MA BL | 28001108 | Blue | 0300 mA | 300 mA | 10 pc(s). | 0.001 kg |
| I-SELECT 2 PLUG 325MA BL | 28001109 | Blue | 0325 mA | 325 mA | 10 pc(s). | 0.001 kg |
| I-SELECT 2 PLUG 350MA BL | 28001110 | Blue | 0350 mA | 350 mA | 10 pc(s). | 0.001 kg |
| I-SELECT 2 PLUG 375MA BL | 28001111 | Blue | 0375 mA | 375 mA | 10 pc(s). | 0.001 kg |
| I-SELECT 2 PLUG 400MA BL | 28001112 | Blue | 0400 mA | 400 mA | 10 pc(s). | 0.001 kg |
| I-SELECT 2 PLUG 425MA BL | 28001251 | Blue | 0425 mA | 425 mA | 10 pc(s). | 0.001 kg |
| I-SELECT 2 PLUG 450MA BL | 28001113 | Blue | 0450 mA | 450 mA | 10 pc(s). | 0.001 kg |
| I-SELECT 2 PLUG 475MA BL | 28001252 | Blue | 0475 mA | 475 mA | 10 pc(s). | 0.001 kg |
| I-SELECT 2 PLUG 500MA BL | 28001114 | Blue | 0500 mA | 500 mA | 10 pc(s). | 0.001 kg |
| I-SELECT 2 PLUG 525MA BL | 28001960 | Blue | 0525 mA | 525 mA | 10 pc(s). | 0.001 kg |
| I-SELECT 2 PLUG 550MA BL | 28001115 | Blue | 0550 mA | 550 mA | 10 pc(s). | 0.001 kg |
| I-SELECT 2 PLUG MAX BL | 28001099 | Blue | MAX | MAX | 10 pc(s). | 0.001 kg |

1. Standards

EN 55015
 EN 61000-3-2
 EN 61000-3-3
 EN 61347-1
 EN 61347-2-13
 EN 62384
 EN 61547

According to EN 50172 for use in central battery systems

According to EN 60598-2-22 suitable for emergency lighting installations

2. Thermal details and life-time

2.1 Expected life-time

Expected life-time

| Type | Output current | ta | 40 °C | 50 °C | 55 °C | 60 °C |
|-------------------------------|----------------|-----------|-------------|-------------|-------------|----------|
| LC 75W 250-550mA flexC Ip EXC | 250 – 550 mA | tc | 55 °C | 65 °C | 70 °C | 75 °C |
| | | Life-time | > 100,000 h | > 100,000 h | > 100,000 h | 50,000 h |

The LED Driver is designed for a life-time stated above under reference conditions and with a failure probability of less than 10 %.

The relation of tc to ta temperature depends also on the luminaire design.

If the measured tc temperature is approx. 5 K below tc max., ta temperature should be checked and eventually critical components (e.g. ELCAP) measured. Detailed information on request.

3. Installation / wiring

3.1 Circuit diagram

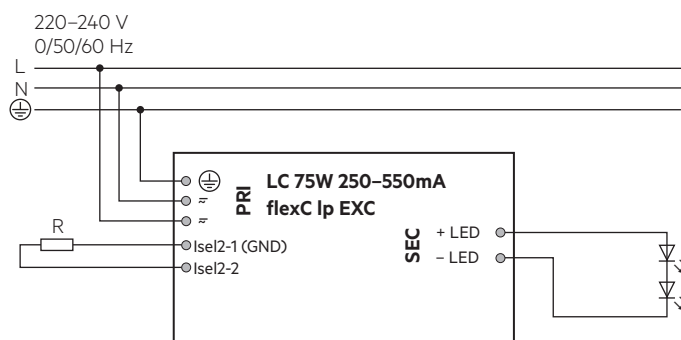

For wiring in dimming operation refer to the ready2mains Gateway data sheet.

3.2 Wiring type and cross section

Solid wire with a cross section of 0.5 – 1.5 mm². Strip 8 – 9 mm of insulation from the cables to ensure perfect operation of terminals.

LED module/LED Driver/supply

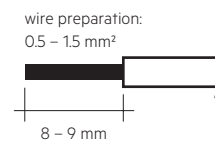

3.3 Loose wiring

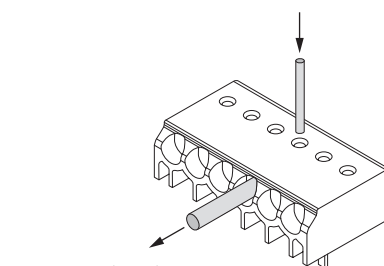

Loosen wire through twisting and pulling or using a Ø 1 mm release tool

3.4 Wiring guidelines

- The cables should be run separately from the mains connections and mains cables to ensure good EMC conditions.
- The LED wiring should be kept as short as possible to ensure good EMC. The max. secondary cable length is 2 m (4 m circuit).
- Secondary switching is not permitted.
- The LED Driver has no inverse-polarity protection on the secondary side. Wrong polarity can damage LED modules with no inverse-polarity protection.
- Wrong wiring of the LED Driver can lead to malfunction or irreparable damage.

3.5 Hot plug-in

Hot plug-in is not supported due to residual output voltage of > 0 V. If a LED load is connected, the device has to be restarted before the output will be activated again. This can be done via mains reset or via interface ready2mains.

3.6 Earth connection

The earth connection is conducted as protection earth (PE). If the LED Driver will be earthed, protection earth (PE) has to be used. There is no earth connection required for the functionality of the LED Driver. Earth connection is recommended to improve following behaviour:

- Electromagnetic interferences (EMI)
- Transmission of mains transients to the LED output

In general it is recommended to earth the LED Driver if the LED module is mounted on earthed luminaire parts respectively heat sinks and thereby representing a high capacity against earth.

3.7 I-select 2 resistors connected via cable

For details see:
http://www.tridonic.com/com/en/download/technical/LCA_PRE_LC_EXC_ProductManual_en.pdf.

4. Electrical values

4.1 Operating window

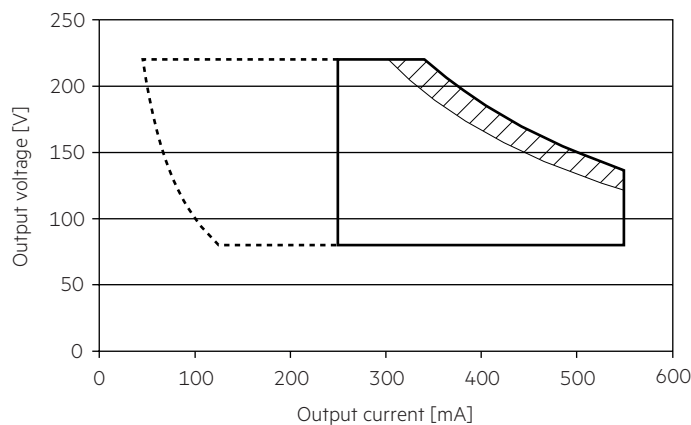

- Operating window 100 %
- - - - - Operating window dimmed
- ▨ LED modules having their non-dimmed operating point within this area can be dimmed down to 15 % light level. For loads outside this area, the achievable minimum dimming level is higher.

Make sure that the LED Driver is operated within the given window under all operating conditions. Special attention needs to be paid at dimming and DC emergency operation as the forward voltage of the connected LED modules varies with the dimming level, due to the implemented amplitude dimming technology. Coming below the specified minimum output voltage of the LED Driver may cause the device to shut-down. See chapter "6.8 DC emergency operation" for more information.

4.2 Efficiency vs load

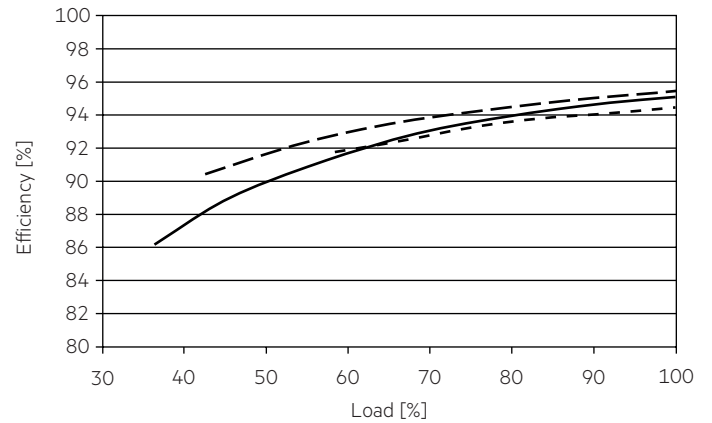

4.3 Power factor vs load

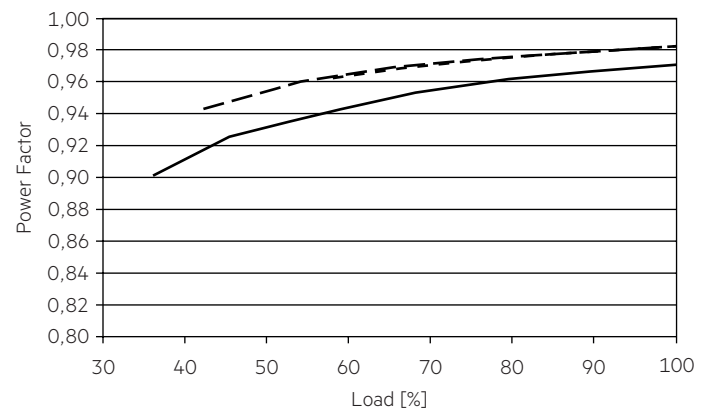

4.4 THD vs load

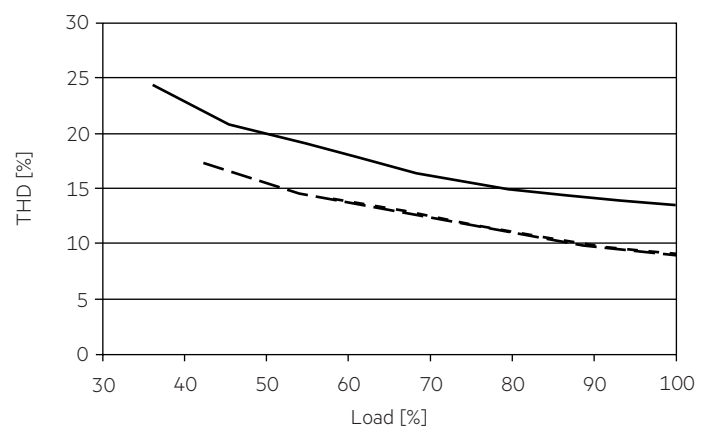

- 250 mA
- - - - - 400 mA
- · - · - 550 mA

100 % load corresponds to the max. output power (full load) according to the table on page 2.

4.5 Maximum loading of automatic circuit breakers

| Automatic circuit breaker type | C10 | C13 | C16 | C20 | B10 | B13 | B16 | B20 | Inrush current | |
|--------------------------------------|---------------------|---------------------|---------------------|---------------------|---------------------|---------------------|---------------------|---------------------|------------------|--------|
| Installation Ø | 1.5 mm ² | 1.5 mm ² | 2.5 mm ² | 2.5 mm ² | 1.5 mm ² | 1.5 mm ² | 2.5 mm ² | 2.5 mm ² | I _{max} | time |
| LC 75W 250-550mA flexC Ip EXC | 10 | 13 | 16 | 21 | 6 | 8 | 10 | 12 | 57.7 A | 217 µs |

Calculation uses typical values from ABB series S200 as a reference.

Actual values may differ due to used circuit breaker types and installation environment.

4.6 Harmonic distortion in the mains supply (at 230 V / 50 Hz and full load) in %

| | THD | 3. | 5. | 7. | 9. | 11. |
|--------------------------------------|------|-----|-----|-----|-----|-----|
| LC 75W 250-550mA flexC Ip EXC | < 10 | < 7 | < 5 | < 5 | < 4 | < 3 |

4.7 Dimming

Dimming range 15 to 100%

The minimum achievable dimming level depends on the connected load.

The operating window shows the minimum reachable power in dimmed state. For loads below the max. output power, the minimum dimming level can be higher.

To determine the minimum dimming level for a certain load carefully read the operating window.

For further information please refer to your Tridonic sales contact.

5. Interfaces / communication

5.1 Control input ready2mains (L, N)

The digital ready2mains protocol is modulated onto the mains signal which is wired to the mains terminal (L and N).

6. Functions

6.1 Function: adjustable current

The output current of the LED Driver can be adjusted in a certain range. For adjustment there are two options available.

Option 1: I-select 2

By inserting a suitable resistor or third party resistor into the I-select 2 interface, the current value can be adjusted. The relationship between output current and resistor value can be found in the chapter "Accessories I-SELECT 2 Plugs".



Please note that the resistor values for I-select 2 are not compatible with I-select (generation 1). Installation of an incorrect resistor may cause irreparable damage to the LED module(s).

Resistors for the main output current values can be ordered from Tridonic (see accessories).

Option 2: ready2mains

Adjustment is done by the ready2mains programmer and the corresponding configuration software (see ready2mains documentation).



Current adjustment can only be done five times over ready2mains. To program the LED Driver a connected load is necessary that is within the operating window of the LED Driver.

The priority for current adjustment methods is I-select 2 followed by ready2mains (lowest priority).

6.2 ready2mains – configuration

The ready2mains interface enables the configuration of the mostly used parameters via the mains wiring.

In the case of EXC LED Driver, it is the LED output current as well as an optional lockbit to prevent any accidental configuration at a later stage.

The configuration is done via the ready2mains Programmer, either directly at the Programmer itself or via a respective software tool. For details on the configuration via ready2mains see the technical information of the Programmer and its tools.

6.3 ready2mains – dimming

The ready2mains interface also allows for mains-based group dimming, without the need for dedicated control wires.

The dimming commands from the control unit are transferred into the digital ready2mains protocol by a ready2mains Gateway. This device then broadcasts the dimming signal to all connected LED drivers via the mains wiring. For details on the dimming functionality via ready2mains see the technical information to ready2mains as well as to the Gateways.

6.4 Short-circuit behaviour

In case of a short-circuit at the LED output the LED output is switched off. After restart of the LED Driver the output will be activated again. The restart can either be done via mains reset or via interface ready2mains.

6.5 No-load operation

The LED Driver will not be damaged in no-load operation. The output will be deactivated and is therefore free of voltage. If a LED load is connected the device has to be restarted before the output will be activated again.

6.6 Overload protection

If the output voltage range is exceeded the LED Driver turns off the LED output. After restart of the LED Driver the output will be activated again. The restart can either be done via mains reset or via interface ready2mains.

6.7 Overtemperature protection

The LED Driver is protected against temporary thermal overheating. If the temperature limit is exceeded the output current of the LED module(s) is reduced. The temperature protection is activated approx. +5 °C above t_c max (see page 2). On DC operation this function is deactivated to fulfill emergency requirements.

6.8 DC emergency operation

The LED Driver is designed to operate on DC voltage and pulsed DC voltage. For a reliable operation, make sure that also in DC emergency operation the LED Driver is run within the specified conditions as stated in chapter "4.1 Operating window".

Light output level in DC operation (EOF_i): 50 % (cannot be adjusted)

The voltage-dependent input current of Driver incl. LED module is depending on the used load.

The nominal voltage-dependent no-load current of Driver (without or defect LED module) is for:

AC: < 23 mA (at 230 V)

DC: 5 – 7 mA (at 186 – 275 V, 0 Hz)

7. Miscellaneous

7.1 Isolation and electric strength testing of luminaires

Electronic devices can be damaged by high voltage. This has to be considered during the routine testing of the luminaires in production.

According to IEC 60598-1 Annex Q (informative only!) or ENEC 303-Annex A, each luminaire should be submitted to an isolation test with 500 V_{DC} for one second. This test voltage should be connected between the interconnected phase and neutral terminals and the earth terminal.

The isolation resistance must be at least 2 MΩ.

As an alternative, IEC 60598-1 Annex Q describes a test of the electrical strength with 1500 V_{AC} (or 1.414 x 1500 V_{DC}). To avoid damage to the electronic devices this test must not be conducted.

7.2 Conditions of use and storage

Environmental conditions: 5 % up to max. 85 %,
not condensed
(max. 56 days/year at 85 %)

Storage temperature: -40 °C up to max. +80 °C

The devices have to be acclimatised to the specified temperature range (t_a) before they can be operated.

7.3 Additional information

Additional technical information at www.tridonic.com → Technical Data

Guarantee conditions at www.tridonic.com → Services

Life-time declarations are informative and represent no warranty claim.
No warranty if device was opened.