



SMART Sensor 10DPI 19fe

Ambient light sensor and presence detector for lighting control

Product description

- Optional ambient light sensor and presence detector for PCA EXCEL one4all devices from the xttec II generation
- Can be remote controlled
- Max. installation height 10 m
- Compact dimensions for luminaire installation
- Simple cable connection to the ballast via SMART interface
- Power supply via ballast
- Lighting control and presence detection can be deactivated
- Individual adjustment of the parameters with configuration software
- Optional with corridorFUNCTION profile
- Optional connection with second ballast possible via accessory cable
- 5-year guarantee

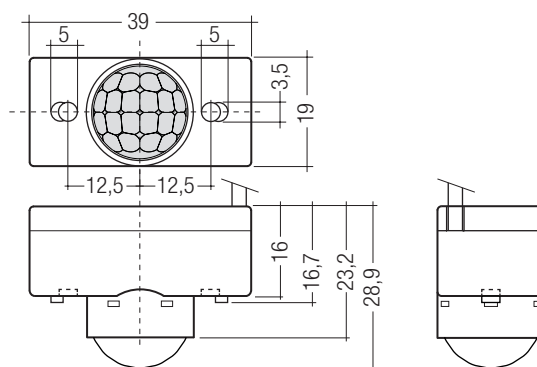

Technical data

Power supply via	SMART interface
Current draw	1 mA from SMART interface
Operating temperature	0 ... +60 °C
Storage temperature	-20 ... +65 °C
Type of protection	IP20
Max. casing temperature tc	63 °C



Standards, page 5

Wiring diagrams and installation examples, page 6, 7

Ordering data

Type	Article number	Packaging, carton
SMART Sensor 10DPI 19fe	28000923	20 pc(s).
SMART Sensor 10DPI 19fe cF n.o.	28000926	20 pc(s).
SMART Sensor 10DPI 19fe cF 01	28000924	20 pc(s).
SMART Sensor 10DPI 19fe cF 30	28000925	20 pc(s).

Specific technical data

Type	Detection				Max. cable length	Control output (devices)	corridorFUNCTION profile
	Light detection angle symmetric	Light measurement at the sensor head ¹⁾	Illuminance (factory default) ²⁾	Motion detection angle symmetric			
SMART Sensor 10DPI 19fe	38°	40 – 1,000 lx	500 lx	93°	0.8 m	2	–
SMART Sensor 10DPI 19fe cF n.o.	38°	40 – 1,000 lx	500 lx	93°	0.8 m	2	never off
SMART Sensor 10DPI 19fe cF 01	38°	40 – 1,000 lx	500 lx	93°	0.8 m	2	switch-off 1 minute
SMART Sensor 10DPI 19fe cF 30	38°	40 – 1,000 lx	500 lx	93°	0.8 m	2	switch-off 30 minutes

¹⁾ The measured value at the sensor head corresponds to approx. 60 to 3000 lux on the surface measured.

²⁾ The illuminance is set for a room defined by Tridonic. Depending on the actual room (reflectance) the measured illuminance may deviate from this value. The illuminance should therefore be checked in the installation and adjusted if necessary.

SMART Sensor T5 Clip + Cap

Product description

- Clip for mounting the sensor directly to the lamp and cover to protect against indirect light



Ordering data

Type	Article number	Packaging, bag	Packaging, carton
SMART Sensor T5 Clip + Cap	86459499	10 pc(s).	200 pc(s).

SMART Sensor T8 Clip + Cap

Product description

- Clip for mounting the sensor directly to the lamp and cover to protect against indirect light



Ordering data

Type	Article number	Packaging, bag	Packaging, carton
SMART Sensor T8 Clip + Cap	86459500	10 pc(s).	200 pc(s).

SMART Sensor Cap

Product description

- Cover to protect against indirect light



Ordering data

Type	Article number	Packaging, bag	Packaging, carton
SMART Sensor Cap	86459501	50 pc(s).	500 pc(s).

REMOTECONTROL IR6

Product description

- Optional infra-red remote control
- Switching on and off (On/Off button)
- Dimming (Up/Down button)
- Activation of automatic lighting control
- Setting the threshold control point (Set button)

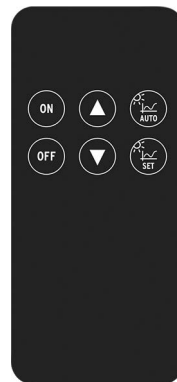

Ordering data

Type	Article number	Dimensions L x W x H	Packaging carton
REMOTECONTROL IR6	28000647	86.5 x 40.5 x 7.2 mm	500 pc(s).

SMART Sensor Extension Cable

Product description

- Cable for optional connection of the sensor with a second ballast
- Only use with SMART Sensor 19fe



Ordering Data

Type	Article number	Length	Packaging, carton
SMART Sensor Extension Cable	86459176	0.8 m	1,500 pc(s).

SMART Sensor 10DPI 19fe

In combination with the PCA EXCEL one4all based on the xitec II platform, SMART Sensor 10DPI 19fe provides the basis for an easy-to-use and cost effective lighting system.

When the sensor detects movement it triggers a predefined motion detection profile in the ballast.

Constant lighting control acts exclusively on the "presence value".

As the amount of natural ambient light changes the illuminance from the artificial lighting system is adjusted accordingly.

With a SMART Sensor 10DPI 19fe installed, PCA EXCEL one4all based on the xitec II platform, can be switched on and off via DSI or DALI signals, switchDIM or the mains.

With the sensor installed the setpoint value (dimming) can be temporarily changed by means of DALI or switchDIM.

Set point can be changed and set via REMOTECONTROL IR6 on the sensor.

The configuration of the sensors is done via masterCONFIGURATOR software tool (version 2.02 or higher).

For further information please refer to the xitec II documentation.

Standards

EN 61547

EN 61347-1

EN 61347-2-11

EN 55015

Installation

- Before connecting / disconnecting the sensor to / from the SMART interface the power supply has to be switched off
- Only for the use of ballasts with xitec II label
- The SMART Sensors have to be connected only to the SMART interface of PCA EXCEL one4all based on the xitec II range
- The SMART interface is not SELV
The installation instructions for mains voltage therefore apply
- Please ensure that the detection range of the sensor lies in the lighting area of the controlled luminaires.
- Please ensure that the detection ranges of the sensors do not overlap. This may have influence to the lighting control.
- Heaters, fans, printers and copiers located in the detection zone may cause incorrect presence detection.
- To avoid false readings, the sensor should be installed so there is no direct light from the lamp in the detection zone.

- The back side of the sensor should not be exposed to the light output of the lamp as this can negatively influence the operation of the sensor.
To avoid any malfunction we strongly recommend:
 - Use the SMART Sensor cap (which can be ordered as accessories) or
 - Alternatively: Mount the sensor away from light exposure from behind
- To avoid false measurements caused by the light from other luminaires we recommend that the sensor should be located centrally in the luminaire.
- Sensor wires must be routed separately from the lamp wires and mains cables otherwise the lighting control system may malfunction. If separate routing is not possible (for reasons of space) shielded lamp wires and mains cables must be used.
- Application wiring and functionality see separate user manual smartSENSOR.

Mounting with cams at the sensor housing:

On the housing of the sensor are fixing cams integrated. With this cams the sensor can be mounted directly in the luminaire housing.

Size of the sheet: 0.8 – 1.2 mm

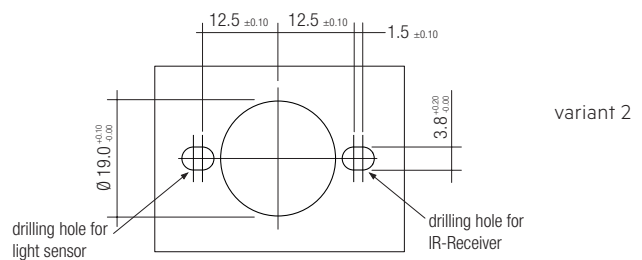
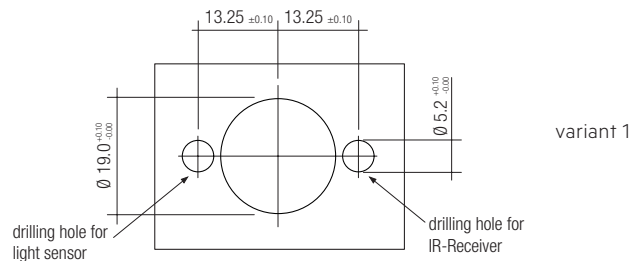

Note:

By the installation is to be paid attention to the fact that the IR sensor and the light sensor is visible.

Set-up

Note: To ensure that the sensor is recognised by the ballast it must be connected to the SMART interface of the ballast before input voltage is applied to the ballast.

A)

corridorFUNCTION with integrated motion sensor

Soft start of PCA EXCEL one4all is followed by activation of motion detection and constant light control.

B)

corridorFUNCTION with external motion sensor

The corridorFUNCTION is activated when a standard motion sensor is connected to the central interface (D1, D2). If movement is detected by the motion sensor the PCA EXCEL one4all ballasts switch on; if no movement is detected they switch to the “absence value” after the delay time on the motion sensor.

Only the “presence value” is constant light controlled.

For the corridorFUNCTION profile there will be used the profile of the sensor.

The motion detector integrated in the SMART Sensor is inactive in this mode.

C)

Compatibility with the controllers must be checked before a PCA EXCEL one4all with connected SMART Sensor 10DPI is integrated in a DSI or DALI light management system.

DSI

Switch ON/OFF via DSI command. DSI command = 0 zero-power switch OFF, DSI commands > 0 switch ON.

ON means activation of the motion detector by sensor.

DALI

Switch ON/OFF via DALI commands.

Control possible via DALI commands.

For more information see the x!tec II documentation.

Extension with SMART Sensor Extension Cable

If DALI is used both ballasts must be in the same group and control must be via group commands.

D)

switchDIM

PCA EXCEL one4all with switchDIM function can be switched ON/OFF by a short key press. By dimming up and down with a long press the set-point of the light control can be changed temporarily. After switching OFF and ON again the previous setted value will be activated again.

If presence control and switchDIM are used in combination there may be loss of synchronism if several ballasts are connected to the same momentary-action switch and the ballasts or the sensors connected to them are large distances apart.

If a second ballast is added by means of a SMART Sensor Extension Cable the control inputs of both ballasts must be connected together (DALI, DSI, switchDIM or corridorFUNCTION).

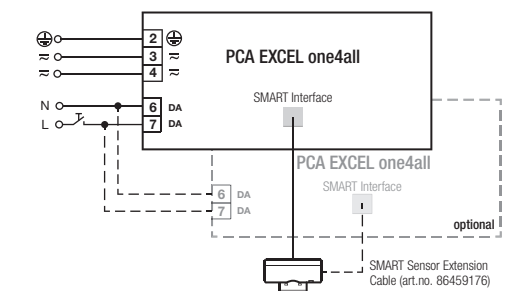
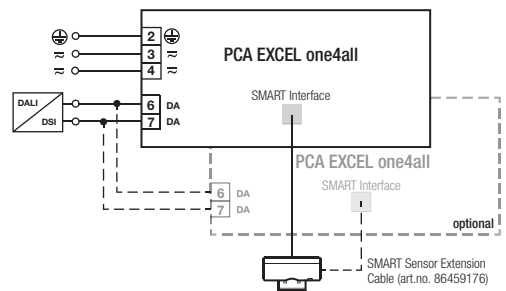
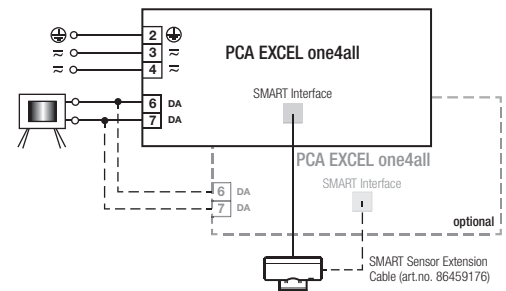
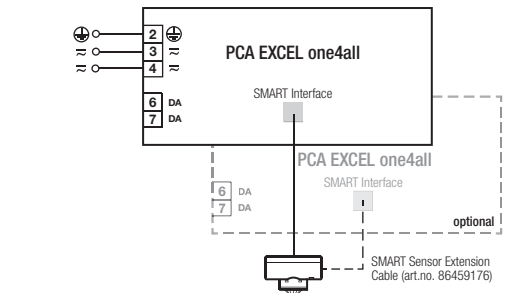

Light regulation

Precise light measurement via photo diodes.

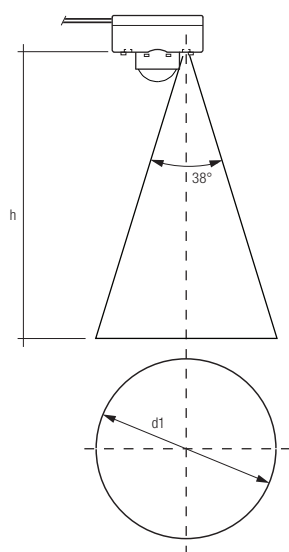

h	d1	d2
2.0 m	1.4 m	4.2 m
3.0 m	2.1 m	6.3 m
4.0 m	2.8 m	8.4 m
5.0 m	3.5 m	10.5 m
6.0 m	4.2 m	12.6 m
7.0 m	4.9 m	14.8 m
8.0 m	5.6 m	16.9 m
9.0 m	6.3 m	19.0 m
10.0 m	7.0 m	21.1 m

Calculation of the diameter:
 $d = 2 \times \tan(0,5 \times \alpha) \times h$

The sensor detection zone is dimensioned so that the entire work area is covered and evaluated, not just a single point.

This ensures that false readings are not made as a result of moving objects across the work surface such as white paper, which would otherwise lead to a sudden change in the brightness level.

The absolute value depends on the luminaire used and the reflectance in the room. The rate at which the dimming value is changed is dynamically linked to the overall lighting level.

The following operating modes can be set for lighting control via the masterCONFIGURATOR configuration software (version 2.02 or higher):

Active	Constant light control is active.
Inactive	Constant light control is deactivated. The lighting switches to a defineable value.

Permanent change of light control set point

The Up/Down button on the remote control enables the setpoint value to be changed temporarily. Pressing the Set button on the remote control stores the setpoint value permanently. The light source indicates that the value has been stored successfully by flashing twice.

In DALI operation the setpoint can be adjusted also with the masterCONFIGURATOR (version 2.02 or higher).

The DALI "RESET" command restores the default value set at the factory.

Bright-out

If the nominal illuminance (e.g. 500 lux) is exceeded by more than 150% (e.g. 750 lux), the lighting is switched off even if motion is detected. The lighting is switched on again when the measured light value falls below the setpoint.

This function can be adjusted via the masterCONFIGURATOR (version 2.02 or higher).

Presence detection

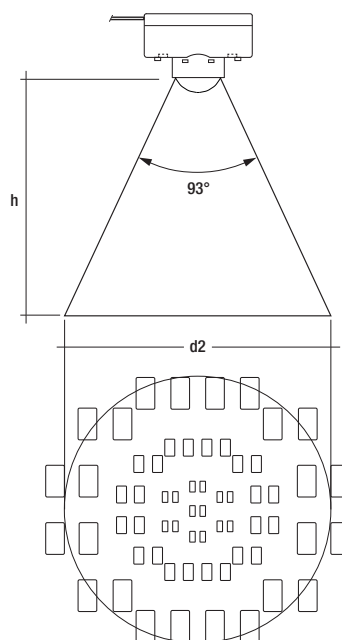

Detection area:
46.5°
Scope:
10 m motion detection

The following operating modes can be set for the motion detector via the masterCONFIGURATOR configuration software (version 2.02 or higher):

Active	The light is switched on or off automatically depending on whether or not there is a person in the room.
Only Off	The motion detector only switches the connected lighting off. The luminaires are switched on manually via the connected external switch or infra-red control.
Never Off	If it has not detected any movement the sensor dims to the "Absence value" parameter and remains at this value
Inactive	The motion sensor is deactivated. The light must be switched on or off manually.

Run-on time

The time that starts as soon as the presence of a person is no longer detected. If the presence of a person is detected again during the run-on time the run-on time is restarted from zero. If no presence is detected during the run-on time the fade time is started as soon as the run-on time expires.

Fade time

The time during which the luminous intensity is faded from the presence value to the absence value.

Switch off delay

The time during which the absence value is held before the lighting is switched off. Depending on the profile selected the switch-off delay may have different values or may not be defined.

Absence value

The luminous intensity when there is no person present.

Presence value

The luminous intensity when persons are present.

Dead time "Manual-off"

If the system is switched off manually via the switch or REMOTECONTROL IR6 the motion sensor is deactivated. At the end of a delay time if motion has not been detected the motion sensor is activated again. If the sensor detects motion during the "Manual-off" delay, the time will be reset to the start.

General settings

Parameter	Default Values
Motion Detector	enabled, on/off
Light Regulation	enabled
Setpoint Light Regulation	500 lx
Bright-out timeout	0 min
Bright-out threshold	150 %
Switch On Value	auto (calculated)

Default Parameter Motion Detector

Parameter	Default Values	Adjustable range
1 Fade-in time	< 0.7 s	–
A Presence value	controlled	Absence value to 100 %
2 Run-on time	20 min	10 s to 42.4 min
3 Fade time	32 s	0 – 90.5 s
B Absence value	10 %	0 % to presence value
4 Switch-off delay	never off / 1 min / 30 min	0 s to 42.3 min / never off
5 Fade-off time	< 0.7 s	–
Manual-off	20 min	3 s to 42.5 min

