

Driver LCI 35W 900mA-1750mA TOP Ip

TOP series

Product description

- Fixed output built-in LED Driver
- Constant current LED Driver
- Output current settable 900 – 1750 mA
- Max. output power 35 W
- Nominal life-time up to 100,000 h
- For luminaires of protection class I and protection class II
- 5-year guarantee

Properties

- Low-profile metal casing with white cover
- Type of protection IP20

Functions

- Intelligent Temperature Guard (overtemperature protection)
- Short-circuit proof
- Overload protection
- Suitable for emergency escape lighting systems acc. to EN 50172



Standards, page 4



IP20 SELV RoHS

Driver LCI 35W 900mA–1750mA TOP Ip

TOP series

Technical data

Rated supply voltage	220 – 240 V
AC voltage range	198 – 264 V
DC voltage range	176 – 280 V (start \geq 198 V DC)
Mains frequency	0 / 50 / 60 Hz
Overvoltage protection	320 V AC, 48 h
Leakage current (PE)	< 0.5 mA
Max. input power	42 W
Efficiency (at 230 V, 50 Hz, full load)	84 – 88 %
THD (at 230 V, 50 Hz, full load)	< 10 %
Output current tolerance ^①	\pm 5 %
Output LF current ripple (< 120 Hz)	< 2 %
Max. peak output current	Output current + 20 %
Max. output voltage (no-load voltage)	60 V
Time to light	< 0.5 s
Switchover time (AC/DC)	< 0.5 s
Burst / surge peaks output side against PE	2 kV
Dimensions L x W x H	360 x 30 x 21 mm

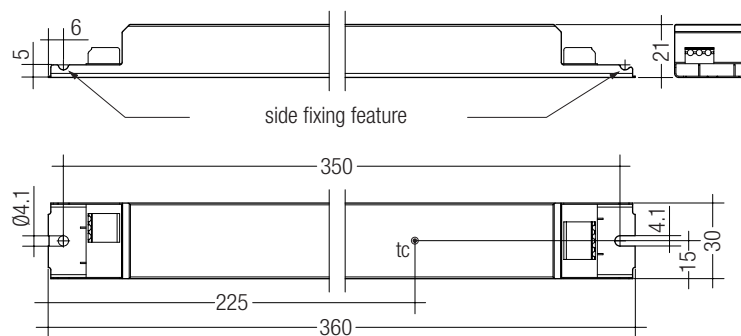

Ordering data

Type	Article number	Packaging carton	Packaging pallet	Weight per pc.
LCI 35W 900mA-1750mA TOP Ip	28000440	10 pc(s).	760 pc(s).	0.238 kg

Specific technical data

Type	Output current ^①	Min. forward voltage	Max. forward voltage	Max. output power	Input power (at 230 V, 50 Hz, full load)	Input current (at 230 V, 50 Hz, full load)	λ (at 230 V, 50 Hz, full load)	tc point	Ambient temperature ta	tc/ta for \geq 50,000 h	I sel resistor value
LCI 35W 900mA-1750mA TOP Ip	900 mA	17.5 V	38.9 V	35 W	40.0 W	181 mA	0.96	85 °C	-25 ... +65 °C	85 / 65 °C	open circuit
	950 mA	16.6 V	36.8 V	35 W	40.2 W	182 mA	0.96	85 °C	-25 ... +65 °C	85 / 65 °C	69.80 k Ω
	1,000 mA	15.8 V	35.0 V	35 W	40.3 W	183 mA	0.96	85 °C	-25 ... +65 °C	85 / 65 °C	64.90 k Ω
	1,050 mA	15.0 V	33.3 V	35 W	40.3 W	183 mA	0.96	85 °C	-25 ... +65 °C	85 / 65 °C	56.00 k Ω
	1,100 mA	14.3 V	31.8 V	35 W	40.5 W	183 mA	0.96	85 °C	-25 ... +65 °C	85 / 65 °C	47.50 k Ω
	1,150 mA	13.7 V	30.4 V	35 W	40.7 W	184 mA	0.96	85 °C	-25 ... +65 °C	85 / 65 °C	43.20 k Ω
	1,200 mA	13.1 V	29.2 V	35 W	40.9 W	185 mA	0.96	85 °C	-25 ... +65 °C	85 / 65 °C	40.20 k Ω
	1,250 mA	12.6 V	28.0 V	35 W	41.1 W	186 mA	0.96	85 °C	-25 ... +65 °C	85 / 65 °C	36.50 k Ω
	1,300 mA	12.1 V	26.9 V	35 W	41.2 W	187 mA	0.96	85 °C	-25 ... +65 °C	85 / 65 °C	32.40 k Ω
	1,350 mA	11.7 V	25.9 V	35 W	41.3 W	187 mA	0.96	85 °C	-25 ... +65 °C	80 / 60 °C	28.70 k Ω
	1,400 mA	11.3 V	25.0 V	35 W	41.4 W	188 mA	0.96	85 °C	-25 ... +65 °C	80 / 60 °C	22.00 k Ω
	1,450 mA	10.9 V	24.1 V	35 W	41.5 W	188 mA	0.96	85 °C	-25 ... +65 °C	80 / 60 °C	17.80 k Ω
	1,500 mA	10.5 V	23.3 V	35 W	41.5 W	188 mA	0.96	85 °C	-25 ... +65 °C	80 / 60 °C	15.00 k Ω
	1,550 mA	10.2 V	22.6 V	35 W	41.7 W	189 mA	0.96	85 °C	-25 ... +65 °C	80 / 60 °C	12.10 k Ω
	1,600 mA	9.8 V	21.9 V	35 W	41.6 W	188 mA	0.96	85 °C	-25 ... +65 °C	80 / 60 °C	9.30 k Ω
	1,650 mA	9.5 V	21.2 V	35 W	41.7 W	189 mA	0.96	85 °C	-25 ... +65 °C	80 / 60 °C	6.49 k Ω
	1,700 mA	9.3 V	20.6 V	35 W	41.8 W	189 mA	0.96	85 °C	-25 ... +65 °C	80 / 60 °C	3.83 k Ω
1,750 mA	9.0 V	20.0 V	35 W	42.0 W	189 mA	0.97	85 °C	-25 ... +65 °C	80 / 60 °C	short circuit	

^① Output current is mean value.

I-SELECT PLUG TOP / ECO

Product description

- Ready-for-use resistor to set output current value
- Resistor is base isolated
- Resistor power 0.25 W
- Resistor value tolerance $\pm 1\%$

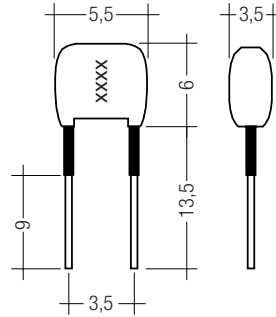
**Ordering data**

Type	Article number	Colour	Marking	Resistor value	Packaging bag	Weight per pc.
I-SELECT PLUG 950mA BR	28000370	Brown	0950	69.80 k Ω	10 pc(s).	0.001 kg
I-SELECT PLUG 1000mA BR	28000459	Brown	1000	64.90 k Ω	10 pc(s).	0.001 kg
I-SELECT PLUG 1050mA BR	28000279	Brown	1050	56.00 k Ω	10 pc(s).	0.001 kg
I-SELECT PLUG 1100mA BR	28000460	Brown	1100	47.50 k Ω	10 pc(s).	0.001 kg
I-SELECT PLUG 1200mA BR	28000461	Brown	1200	40.20 k Ω	10 pc(s).	0.001 kg
I-SELECT PLUG 1300mA BR	28000462	Brown	1300	32.40 k Ω	10 pc(s).	0.001 kg
I-SELECT PLUG 1400mA BR	28000280	Brown	1400	22.00 k Ω	10 pc(s).	0.001 kg
I-SELECT PLUG 1500mA BR	28000464	Brown	1500	15.00 k Ω	10 pc(s).	0.001 kg
I-SELECT PLUG 1600mA BR	28000464	Brown	1600	9.30 k Ω	10 pc(s).	0.001 kg
I-SELECT PLUG 1700mA BR	28000464	Brown	1700	3.83 k Ω	10 pc(s).	0.001 kg
I-SELECT PLUG MAX GR	28000274	Grey	MAX	0 Ω	10 pc(s).	0.001 kg

Standards

EN 55015
 EN 61000-3-2
 EN 61000-3-3
 EN 61347-2-13
 EN 62384
 EN 61547

According to EN 50172 for use in central battery systems

According to EN 60598-2-22 suitable for emergency lighting installations

Output current setting

Output current can be set by connecting a resistor between the 2 "I sel" terminals. Relationship between output current and resistor value can be found at the table "Specific technical data". Resistor values specified from standardised resistor value ranges.

Resistor value tolerance has to be $\leq 1\%$.

Resistor power has to be $\geq 0.1\text{ W}$.

If the resistor is connected with wires a max. wire length of 2 m may not be exceeded and possible interferences have to be avoided.

Resistor detection at each start.

Change of the resistor value during the operation will be not considered.

Resistors for the main output current values can be ordered from Tridonic (see accessories).

DC emergency operation

The LED Driver is designed for operation on DC voltage and pulsed DC voltage.

Light output level in DC operation: 100 % (EOFx).

The voltage-dependent input current of Driver incl. LED module is depending on the used load.

The voltage-dependent no-load current of Driver (without or defect LED module) is for:

AC: < 24 mA

DC: < 8 mA

Overload protection

LED Driver will switch off at overload operation. Mains reset is required to restart the LED Driver.

Underload operation

LED Driver will switch off at underload operation. Mains reset is required to restart the LED Driver.

Overtemperature protection

The LED Driver will reduce output current at temporary thermal over-heating (exceeding max. t_c point). On DC operation this function is deactivated to fulfill emergency requirements.

Short-circuit behaviour

LED Driver will switch off in case of short-circuit of LED output. Mains reset is required to restart the LED Driver.

No-load operation or load loss during operation

LED Driver will detect a load loss during operation. In this case and no-load operation the max. output voltage can apply at the LED output for max. 5 s before LED Driver shuts down. Mains reset is required to restart the LED Driver.

Hot plug-in

Hot plug-in is not recommend within 5 s after shutdown due to output voltage of > 0 V. Mains reset is required to restart the LED Driver if LED module is connected to the LED Driver after these 5 s.

Conditions of use and storage

Humidity: 5 % up to max. 85 %,
 not condensed
 (max. 56 days/year at 85 %)

Storage temperature: -40 °C up to max. +80 °C

The devices have to be within the specified temperature range (t_a) before they can be operated.

Temperature range

The LED Driver life duration is related to the ambient temperature t_a .

The relation of t_c to t_a temperature depends also on the luminaire design. If the measured t_c temperature is approx. 5 K below t_c max. or higher, t_a temperature should be checked and eventually critical components (e.g. ELCAP) measured.

Detailed information on request.

Expected life-time

Type	Output current	t_a	40 °C	50 °C	55 °C	60 °C	65 °C
LCI 35W 900mA-1750mA TOP Ip	900 – 1,300 mA	t_c	60 °C	70 °C	75 °C	80 °C	85 °C
		life-time	> 100,000 h	> 100,000 h	> 100,000 h	70,000 h	50,000 h
	1,350 – 1,750 mA	t_c	60 °C	70 °C	75 °C	80 °C	85 °C
		life-time	> 100,000 h	> 100,000 h	70,000 h	50,000 h	35,000 h

x = not permitted

The LED Driver is designed for a life-time stated above under reference conditions and with a failure probability of less than 10 %.

Maximum loading of automatic circuit breakers

Automatic circuit breaker type	C10	C13	C16	C20	B10	B13	B16	B20	Inrush current
Installation Ø	1,5 mm ²	1,5 mm ²	2,5 mm ²	2,5 mm ²	1,5 mm ²	1,5 mm ²	2,5 mm ²	2,5 mm ²	I_{max} time
LCI 35W 900mA-1750mA TOP Ip	45	55	70	90	45	55	70	90	11.2 A 40 µs

Harmonic distortion in the mains supply (at 230 V / 50 Hz and full load) in %

	THD	3.	5.	7.	9.	11.
LCI 35W 900mA-1750mA TOP Ip	< 10	< 6	< 4	< 5	< 4	< 3

Installation instructions**Wiring type and cross section**

Solid wire with a cross section of 0.5 – 1.5 mm². Strip 8 – 9 mm of insulation from the cables to ensure perfect operation of terminals.

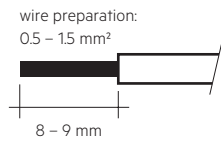
**Release of the wiring**

Loosen wire through twisting and pulling or using a Ø 1 mm release tool.

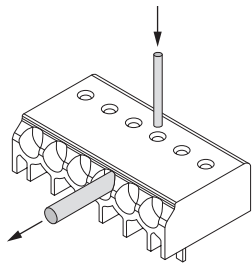
**Wiring guidelines**

- All connections must be kept as short as possible to ensure good EMI behaviour.
- Earthing is not required for the device to operate but will improve the EMI behaviour for protection class I luminaires.
- If LCI TOP C will be earthed protection earth (PE) has to be used.
- Mains leads should be kept apart from LED Driver and other leads (ideally 5 – 10 cm distance)
- Max. length of output and I sel wires is 2 m.
- Secondary switching is not permitted.
- Incorrect wiring can damage LED modules.
- The wiring must be protected against short circuits to earth (sharp edged metal parts, metal cable clips, louver, etc.).

Earth connection

The earth connection is conducted as protection earth (PE). The LED Driver can be earthed via earth terminal or metal housing. If the LED Driver will be earthed, protection earth (PE) has to be used. There is no earth connection required for the functionality of the LED Driver.

Earth connection is recommended to improve following behaviour.

- Electromagnetic interferences (EMI)
- Transmission of mains transients to the LED output

In general it is recommended to earth the LED Driver if the LED module is mounted on earthed luminaire parts respectively heat sinks and thereby representing a high capacity against earth.

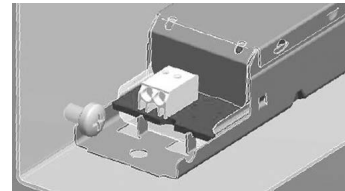
Side fixing feature

Screw M4, screw head diameter 8–10 mm

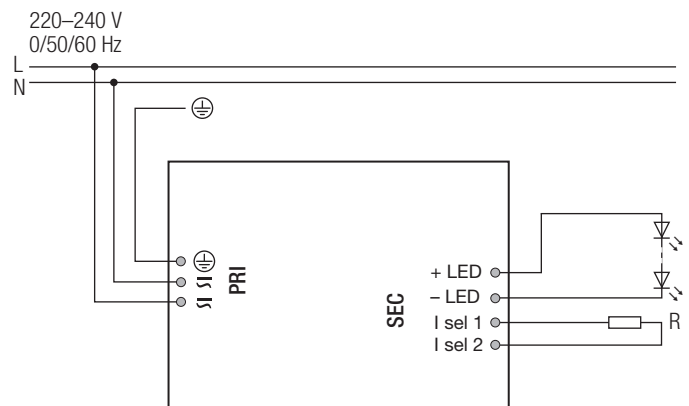
Circuit diagram**Isolation and electric strength testing of luminaires**

Electronic devices can be damaged by high voltage. This has to be considered during the routine testing of the luminaires in production.

According to IEC 60598-1 Annex Q (informative only!) or ENEC 303-Annex A, each luminaire should be submitted to an isolation test with 500 V_{DC} for 1 second. This test voltage should be connected between the interconnected phase and neutral terminals and the earth terminal.

The isolation resistance must be at least 2 MΩ.

As an alternative, IEC 60598-1 Annex Q describes a test of the electrical strength with 1500 V_{AC} (or 1.414 x 1500 V_{DC}). To avoid damage to the electronic devices this test must not be conducted.

Additional information

Additional technical information at www.tridonic.com → Technical Data

Guarantee conditions at www.tridonic.com → Services

Life-time declarations are informative and represent no warranty claim. No warranty if device was opened.

Diagrams LCI 35W 900mA-1750mA TOP Ip

Efficiency vs load

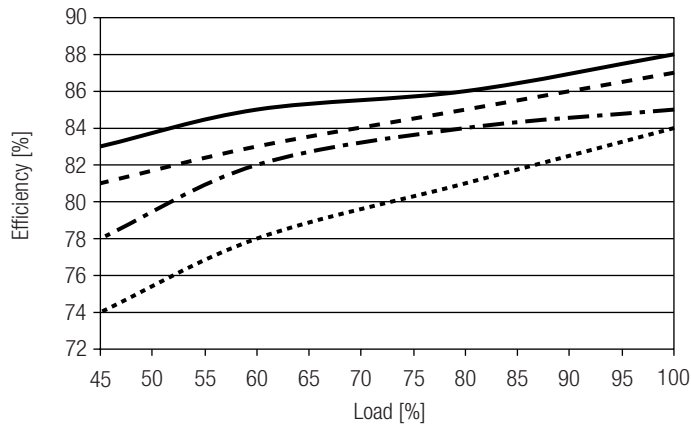

Power factor vs load

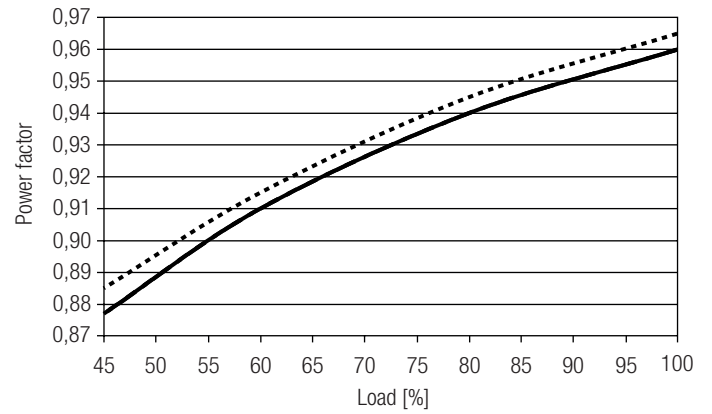

Input power vs load

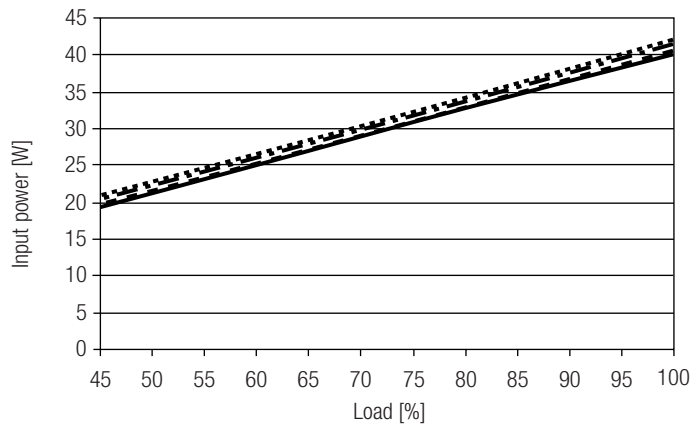

Input current vs load

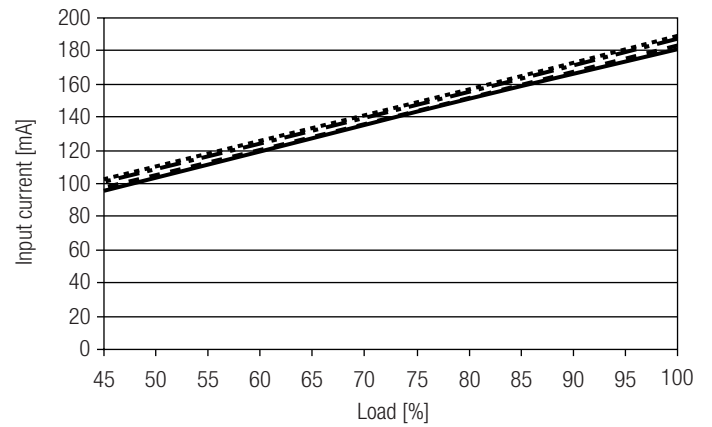

THD vs load

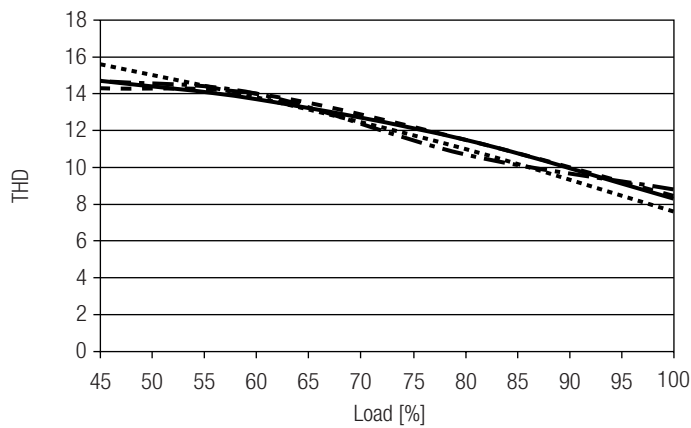

- 900 mA
- - - 1100 mA
- · - 1400 mA
- · · 1750 mA