

## DALI RM

DALI control module for 1 relays

### Product description

- Control of one standard contactor
- 5-year guarantee



**Wiring diagrams and installation examples**, page 4





## DALI RM

DALI control module for 1 relays

### Technical data

Ambient temperature $t_a$	0 ... +50 °C
Type of protection	IP20

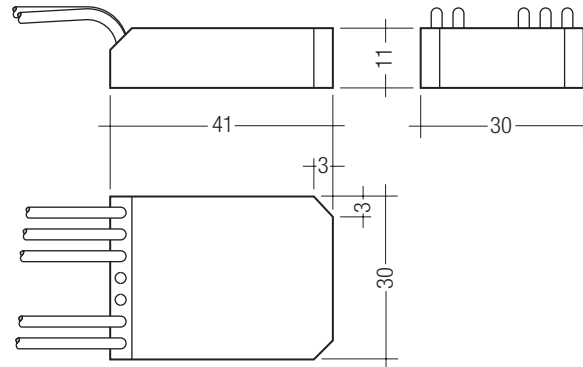

### Ordering data

Type	Article number	Packaging, carton	Weight per pc.
DALI-RM	24034702	1 pc(s).	0.087 kg

### Specific technical data

Type	Inputs			Output, relay			
	DALI control input	Current draw	Number of DALI addresses	Max. switching voltage AC	Max. switching voltage DC	Type of contact	Min. contact load
DALI-RM	1	12 mA from DALI	1	250 V	35 V	1 changeover	1.2 W

### DALI standard

The DALI RM is designed to control control gear with DALI standard IEC 60929 (DALI V0).

### Glow-wire test

according to EN 60598-1 passed.

### Functional description:

- Compact relay module for controlling a standard contactor via DALI.
- Loads that do not have a DALI input can therefore be integrated in the DALI circuit. The loads can be switched on and off via DALI.
- "masterCONFIGURATOR" software is available free of charge at [www.tridonic.com](http://www.tridonic.com) for programming the switch-on and switch-off points.  
"MIN LEVEL": Sets switch off level  
"MAX LEVEL": Sets switch on level  
Factory preset:  
"MIN LEVEL" = 0 → OFF  
"MAX LEVEL" = 100 → ON

### Installation:

- Loads must not be connected directly to the DALI RM. The load must always be switched via an external contactor.
- The maximum load that can be connected to the DALI RM is the load of a contactor coil.
- When selecting the correct contactor please check the inrush currents of the switched loads. Electronic ballasts may have very high inrush currents. Check with the contactor manufacturer.
- If DC contactor coils are controlled they must be equipped with an appropriate free-wheeling diode.
- Relay switches on when ACTUAL LEVEL is above the MAX-LEVEL.

- Relay switches off when ACUTAL LEVEL is below the MIN-LEVEL.
- The DALI RM is powered directly by the DALI line, hence in case of missing supply the relay-contact opens. Therefore the SYSTEM FAILURE LEVEL is meaningless.
- It is not possible to receive information about the state of the loads. Hence error messages do not make sense in this application and QUERY LAMP FAILURE will always send NO as an answer. The QUERY STATUS bits 0&1 are not implemented.
- The physical selection method is not implemented.
- When storing a scene level, besides the ACTUAL LEVEL, the relay state will be stored as well. When storing scenes it is important that the relay is in the required state.
- This is not a separate unit, it is intended for installation.
- DALI is not SELV. The installation instructions for low voltage therefore apply.

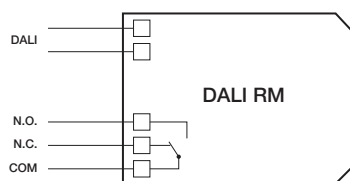

Circuit diagram

Switching of 12/24 VDC contactor coils

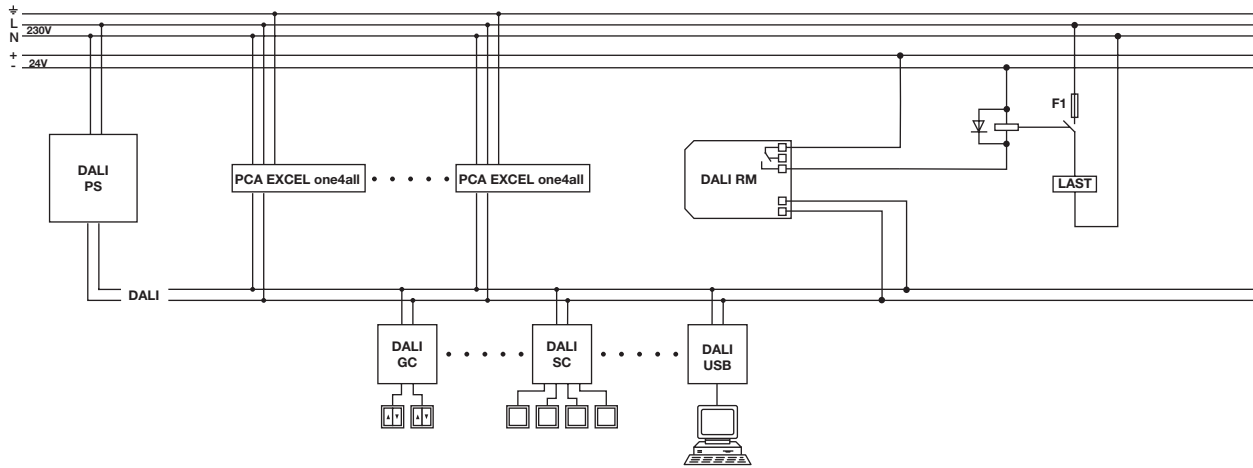

Switching of 230 VAC contactor coils

