



PCA T5 EXCEL one4all Ip x!tec, 3x14/24 W and 4x14/24 W EXCEL T5

Product description

- Processor-controlled ballast with x!tec inside
- Highest possible energy class CELMA EEI = A1 BAT[®]
- Noise-free precise control via DALI or DSI signal, switchDIM or corridorFUNCTION
- Multi-lamp management
- OEM-specific reserved memory areas
- Extended DALI commands
- 5-year guarantee

Interfaces

- DALI
- DSI
- switchDIM (with memory function + selectable dimming rate)
- corridorFUNCTION (individually programmable)

Functions

- Intelligent Temperature Guard (overtemperature protection)
- Intelligent Voltage Guard (overvoltage indication and undervoltage shutdown)
- Optimum filament heating in any dimmer setting
- Disconnection of filament heating from a dimming level of approx. 90 % for maximum energy efficiency (SMART-Heating concept)
- Fade rates between 50 ms and 90 s (min. – max.)
- Automatically triggered emergency lighting value in DC mode, can be set between 1 and 100 %
- For emergency lighting systems as per EN 50172
- Automatic start after replacement of defective lamps
- Automatic shutdown if the lamp is faulty
- Dimming possible in DC mode
- Backwards compatible

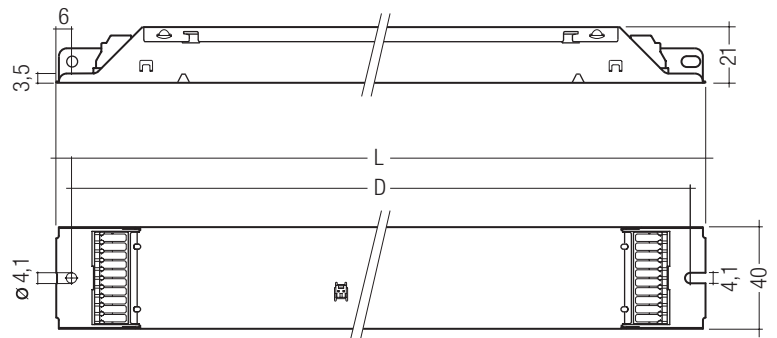

Technical data

Mains voltage range	220 – 240 V
AC voltage range	198 – 264 V
DC voltage range	176 – 280 V (lamp start \geq 198 V DC)
Mains frequency	0 / 50 / 60 Hz
Overvoltage protection	320 V AC, 1 h
Typ. power input on standby	< 0.5 W
Protective hot restart	0.5 s for AC / 0.2 s for DC
Dimming range, 3 lamps	5 – 100 %
Dimming range, 4 lamps	1 – 100 %
Lamp start possible from	5 % (3 lamps), 1 % (4 lamps)
Operating frequency	~ 40 – 100 kHz
Type of protection	IP20

Ordering data

Type	Article number	Packaging, carton	Packaging, pallet	Weight per pc.
For luminaires with 3 lamps				
PCA 3x14/24 T5 EXCEL one4all Ip x!tec	22176209	20 pc(s).	600 pc(s).	0.298 kg
For luminaires with 4 lamps				
PCA 4x14/24 T5 EXCEL one4all Ip x!tec	22176210	20 pc(s).	600 pc(s).	0.340 kg



Standards, page 3

Wiring diagrams and installation examples, page 6

Specific technical data

Lamp wattage	Lamp type	Type	Article number	Dimensions L x W x H	Hole spacing D	Lamp power ^②	Circuit power ^②	EEL	Current at 50 Hz 230 V ^②	λ at 50 Hz 230 V	tc point max.	Ambient temperature ta ^③
For luminaires with 3 lamps												
3 x 14 W	T5	PCA 3x14/24 T5 EXCEL one4all lp xttec	22176209	360 x 40 x 21 mm	350 mm	42 W	46.5 W	A1 BAT	0.21 A	0.97	75 °C	-25 ... 60 °C
3 x 24 W	T5	PCA 3x14/24 T5 EXCEL one4all lp xttec	22176209	360 x 40 x 21 mm	350 mm	72 W	73.0 W	A1 BAT	0.32 A	0.97	75 °C	-25 ... 55 °C
For luminaires with 4 lamps												
4 x 14 W	T5	PCA 4x14/24 T5 EXCEL one4all lp xttec	22176210	360 x 40 x 21 mm	350 mm	56 W	60.5 W	A1 BAT	0.27 A	0.97	75 °C	-25 ... 60 °C
4 x 24 W	T5	PCA 4x14/24 T5 EXCEL one4all lp xttec	22176210	360 x 40 x 21 mm	350 mm	96 W	97.5 W	A1 BAT	0.43 A	0.97	75 °C	-25 ... 50 °C

① According to the EU directives on ecodesign requirements (EC) No. 245/2009 and (EC) No. 347/2010.

② Valid at 100 % dimming level.

③ +10 °C to ta max: unrestricted dimming. -25 °C to +10 °C: unrestricted dimming from 100 % to 30 %.

-25 °C to +10 °C, dimming below 30 %: malfunction possible but no damage to ECG. This applies to AC and DC operation.

Standards

EN 55015
EN 60929
EN 61000-3-2
EN 61347-2-3
EN 61547
Suitable for emergency installations according to EN 50172
CISPR 15
CISPR 22
IEC 60929
IEC 61000-3-2
IEC 61347-2-3
IEC 61547
IEC 62386 (according to DALI standard V1)

Lamp starting characteristics

Warm start
Starting time 0.5 s with AC
Starting time 0.2 s with DC
Start at any dimming level

AC operation

Mains voltage
220–240 V 50/60 Hz
198–264 V 50/60 Hz including safety tolerance ($\pm 10\%$)
202–254 V 50/60 Hz including performance tolerance (+6 % / -8 %)

DC operation

220–240 V 0 Hz
198–280 V 0 Hz certain lamp start
176–280 V 0 Hz operating range
Use in emergency lighting installations according to EN 50172 or for emergency luminaires according to EN 61347-2-3 appendix J.

Light output level in DC operation

Programmable from 1 % to 100 %
Programming by extended DSI or DALI signal (16 bit).
Default value is 15 %
In DC operation dimming mode can be activated.
EBLF = 0.5 x adjusted DC dimming level
(e.g. 0.5 x 0.7).

Emergency units

The "PCA T5 EXCEL Ip xitec" ballasts are compatible with all emergency units from Tridonic. See the table in the data sheet. Also all "5-pole" emergency units can be used. When used with other emergency units tests are necessary.

Temperature range

Unlimited dimming range from 10 °C to ta max.
-25 °C to +10 °C: dimming operation from 100 % to 30 %. If dimm level goes below 30 % malfunction possible, but no electronic ballast damage.
This applies to AC and DC operation.

Mains currents in DC operation (at 70 % light output)

Type	Wattage	Mains current at $U_n = 220 V_{DC}$	Mains current at $U_n = 240 V_{DC}$
PCA 3x14/24 T5 EXCEL one4all Ip xitec	3x14 W	0.17 A	0.16 A
PCA 3x14/24 T5 EXCEL one4all Ip xitec	3x24 W	0.28 A	0.26 A
PCA 4x14/24 T5 EXCEL one4all Ip xitec	4x14 W	0.22 A	0.21 A
PCA 4x14/24 T5 EXCEL one4all Ip xitec	4x24 W	0.37 A	0.34 A

Ballast lumen factor AC operation (AC-BLF) EN 60929 8.1

Type	Wattage	AC-BLF at $U = 230 V_{AC}$
PCA 3x14/24 T5 EXCEL one4all Ip xitec	3x14 W	0.99
PCA 3x14/24 T5 EXCEL one4all Ip xitec	3x24 W	0.99
PCA 4x14/24 T5 EXCEL one4all Ip xitec	4x14 W	0.99
PCA 4x14/24 T5 EXCEL one4all Ip xitec	4x24 W	0.99

The ballast lumen factor for AC operation (AC-BLF) does not alter from $U_n = 198 V_{AC}$ to $U_n = 254 V_{AC}$. The ballast lumen factor for DC operation (DC-BLF) on the basis of an automatic power reduction of the ballasts (default value is 70 %) will be smaller than AC. It does not alter in the DC operating range (198–280 V DC).

Harmonic distortion in the mains supply (at 230 V / 50 Hz)

Type	Wattage	THD	3	5	7	9	11
PCA 3x14/24 T5 EXCEL one4all Ip xitec	3x14 W	8.40	6.65	1.97	2.17	2.09	1.36
PCA 3x14/24 T5 EXCEL one4all Ip xitec	3x24 W	7.98	6.23	1.76	1.75	2.31	1.04
PCA 4x14/24 T5 EXCEL one4all Ip xitec	4x14 W	8.67	6.97	2.85	1.86	1.49	1.19
PCA 4x14/24 T5 EXCEL one4all Ip xitec	4x24 W	7.52	6.37	1.53	1.94	1.04	1.08

Lamp type recognition

Each of the lamps for which the control gear is designed will be operated correctly according to the lamp specification. The currently used lamp is recognised during the start up process.
To avoid an incorrect lamp recognition due to fast multiple ON/OFF switches, new lamp data are only restored if the lamp has operated for at least 5 seconds.

Dimming

Dimming curve is adapted to the eye sensitiveness.

Dimming range:

4-lamp: 1 % to 100 %, 3-lamp: 5 % to 100 %

Digital control with:

- DSI signal: 8 bit Manchester Code
Speed 1 % to 100 % in 1.4 s
- DALI signal: 16 bit Manchester Code
Maximum speed 1 % to 100 % in 550 ms (adjustable between 50 ms and 90 s)
Programmable parameter:
Minimum dimming level
Maximum dimming level
Defaults 3-lamp minimum = 5 %
maximum = 100 %
Defaults 4-lamp minimum = 1 %
maximum = 100 %

Control input (DA/D1, DA/D2)

Digital DALI signal or a push-to-make switch (switchDIM) can be wired on the same terminals (DA and DA).

Digital signal DALI/DSI

The control input is non-polar and protected against accidental connection with a mains voltage up to 264 V. The control signal is not SELV. Control cable has to be installed in accordance to the requirements of low voltage installations.

Different functions depending on each module.

SMART interface

An additional interface for the direct connection of the SMART-LS II Ip¹⁾ light sensor. The sensor registers actual ambient light and maintains the individually defined lux level.

After every mains reset the SMART interface automatically checks for an installed sensor. With the sensor installed the PCA T5 EXCEL one4all Ip x:tec automatically runs in the constant lux level mode. ON/OFF switch via mains, switchDIM or DALI/DSI signal.

DALI/DSI signal = 0 switches off,

DALI/DSI signal ≥ 1 switches on.

With relative DALI dimming commands (e.g. up, down etc.) or switchDIM signals it is possible to change the controlled light level temporarily.

Temporarily means that after a switching cycle OFF/ON command the ballast will start at the preset value determined by the SMART-LS II Ip. The installation of the two wire bus is according to the appropriate low voltage regulations.

switchDIM

Integrated switchDIM function allows a direct connection of a push to make switch for dimming and switching.

¹⁾ SMART-LS II Ip: article number 86458258

Dimming characteristics

PCA T5 EXCEL one4all Ip x:tec

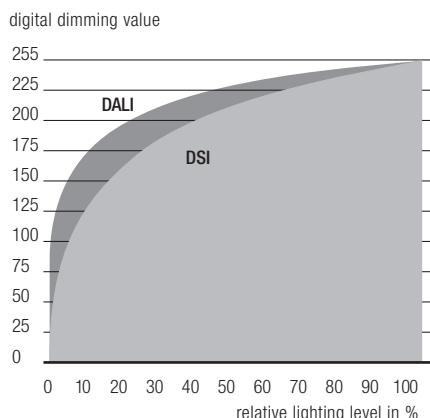

Dimming characteristics as seen by the human eye

Brief push (< 0.6 s) switches ballast ON and OFF. The ballasts switch-ON at light level set at switch-OFF. When the push to make switch is held, PCA ballasts are dimmed. After repush the PCA is dimmed in the opposite direction.

The switchDIM fade time is set to 3 s from min. to max. in the factory settings. With a 20 s push to the push to make switch this fade time can be changed to 6 s. In this instance the switchDIM application will be synchronized to 50 % light level after 10 s and after 20 s the light level rises to 100 % with the new fade time.

At every synchronisation (10 s keystroke) the device will reset to 3 s (factory setting)

In installations with PCAs with different dimming levels or opposite dimming directions (e.g. after a system extension), all PCAs can be synchronized to 50 % dimming level by a 10 s push.

Use of push to make switch with indicator lamp is not permitted.

Deactivation: If the corridorFUNCTION is wrongly activated in a switchDIM system (for example a switch is used instead of pushbutton), there is the option of installing a pushbutton and deactivating the corridorFUNCTION mode by five short pushes of the button within three seconds.

switchDIM and corridorFUNCTION are very simple tools for controlling ballasts with conventional momentary-action switches or motion sensors.

To ensure correct operation a sinusoidal mains voltage with a frequency of 50 Hz or 60 Hz is required at the control input.

Special attention must be paid to achieving clear zero crossings.

Serious mains faults may impair the operation of switchDIM and corridorFUNCTION.

Energy saving

PCA T5 EXCEL one4all Ip x:tec

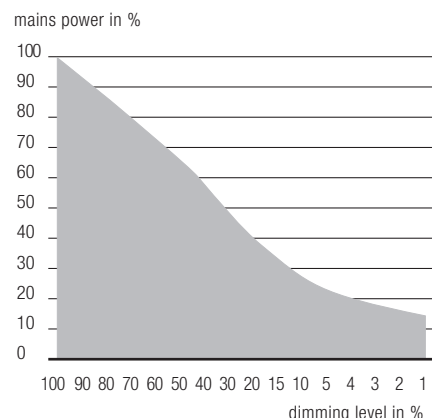

Backwards compatibility:

With a simple key combination a PCA T5 EXCEL Ip x:tec can be reset as a normal PCA EXCEL from the previous generation. Synchronisation simply has to take place three times within one minute (3 x 10 s). To activate the “x:tec” settings again, synchronisation has to take place four times within one minute.

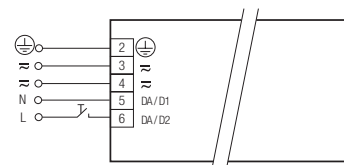

switchDIM PCA T5 EXCEL one4all Ip x:tec

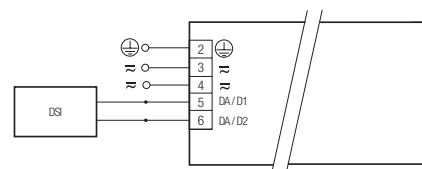

DSI PCA T5 EXCEL one4all Ip x:tec

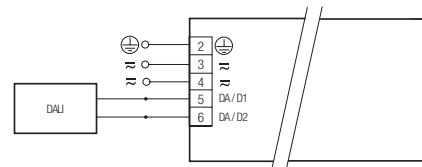

DALI PCA T5 EXCEL one4all Ip x:tec

Dimmable ballasts from Tridonic have to be earthed.

Loading of automatic circuit breakers

Automatic circuit breaker type	C10	C13	C16	C20	B10	B13	B16	B20
Installation Ø	1.5 mm ²	1.5 mm ²	1.5 mm ²	2.5 mm ²	1.5 mm ²	1.5 mm ²	1.5 mm ²	2.5 mm ²
PCA 3x14/24 T5 EXCEL one4all Ip x:tec	16	22	32	36	8	11	16	18
PCA 4x14/24 T5 EXCEL one4all Ip x:tec	14	22	32	34	7	11	16	17

Continuous operation: to calculate the protective safety switch see main current, page 1

corridorFUNCTION

Activation: To activate the corridorFUNCTION a voltage of 230 V simply has to be applied for five minutes at D1, D2. The unit will then switch automatically to the corridorFUNCTION.

Deactivation: If the corridorFUNCTION is wrongly activated in a switchDIM system (for example a switch is used instead of pushbutton), there is the option of installing a pushbutton and deactivating the corridorFUNCTION mode by five short pushes of the button within three seconds.

The corridorFUNCTION V2 offers the added benefit of a second and third preprogrammed profile.

Application and functionality of profiles see user manual corridorFUNCTION.

Intelligent Temperature Guard

The intelligent temperature guard protects the PCA T5 EXCEL Ip x:tec from thermal overheating by reducing the output power or switching off in case of operation above the thermal limits of the luminaire or ballast. Depending on the luminaire design, the ITG operates at about 5 to 10 °C above T_c temperature.

plugADDRESSING – simple handling, commissioning and wiring

The new plug&play solution simplifies handling. By attaching different colored marked plugs to the SMART-Interface, group addresses are assigned to the PCA T5 EXCEL one4all Ip x:tec. This supersedes a single addressing and the devices can be put into operation without any additional programming. Another significant advantage of this concept is in case of exchange and no limits to 64 DALI addresses. Ideal for RGB applications and cost-effective system solutions with simple controllers. Simple – Quick – Plug & Play!

Intelligent Voltage Guard

Intelligent Voltage Guard is the name of the new electronic monitor from Tridonic. This innovative feature of the PCA family of control gear from Tridonic immediately shows if the mains voltage rises above or falls below certain thresholds. Measures can then be taken quickly to prevent damage to the control gear.

- If the mains voltage rises above approx. 305 V (voltage depends on the ballast type), the lamp starts flashing on and off.
- This signal “demands” disconnection of the power supply to the lighting system.
- The active-current-control of these control gears is protected against failure caused by the high mains currents generated as a result of mains undervoltage. The switch off level depends on lamp wattage and is typically < 140 V.

Installation instructions

Wiring type and cross section

The wiring can be solid cable with a cross section of 0.5 to 0.75 mm² for push terminal and 0.5 mm² for IDC terminal. For the push-wire connection you have to strip the insulation (8–9 mm).

wire preparation:
0.5 – 0.75 mm²

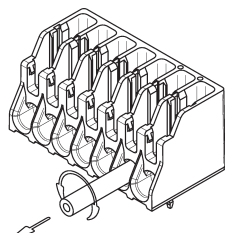
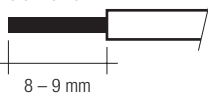

Loosen wire through twisting and pulling

Operating voltage

Type	Wattage	U _{out}
PCA 3x14/24 T5 EXCEL one4all Ip x:tec	3x14 W	430 V
PCA 3x14/24 T5 EXCEL one4all Ip x:tec	3x24 W	430 V
PCA 4x14/24 T5 EXCEL one4all Ip x:tec	4x14 W	430 V
PCA 4x14/24 T5 EXCEL one4all Ip x:tec	4x24 W	430 V

Wiring advice

The lead length is dependent on the capacitance of the cable.

Ballast Type	Terminal			Maximum capacitance allowed			
	Cold	Middle	Hot	Cold	Middle	Hot	
PCA 3x14/24 T5 EXCEL one4all Ip x:tec	7, 8	9, 10, 14, 15, 16, 17	12, 13	100 pF	50 pF	100 pF	
PCA 4x14/24 T5 EXCEL one4all Ip x:tec	14, 15, 16, 17	7, 8, 9, 10	12, 13, 18, 19	200 pF	50 pF	100 pF	

With standard solid wire 0.5/0.75 mm² the capacitance of the lead is 30–80 pF/m.

This value is influenced by the way the wiring is made.

Lamp connection should be made with symmetrical wiring.

3-lamp devices: Hot and cold leads should be separated as much as possible.

4-lamp devices: Middle and hot leads should be separated as much as possible.

Hot leads (9, 10, 15, 16) and cold leads (11, 12, 13, 14) should be separated as much as possible.

When using two or more dimmable ballasts in one luminaire with separate dimming controls, the lamp leads must be kept separate.

Distance to plate: 5 – 10 mm

(ideal distance for optimal symmetrical light)

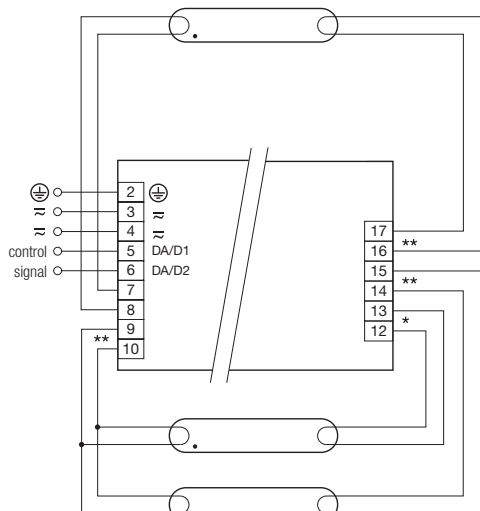

* leads 12, 13: keep wires short, max. 1.0 m
** leads 9, 10, 14, 15, 16, 17: keep wires short, max. 0.5 m
leads 7, 8: max. 2.0 m

PCA T5 EXCEL one4all Ip xitec 3x14/24 W

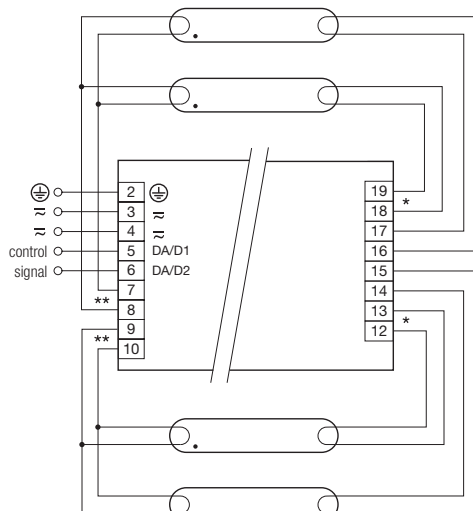

* leads 12, 13, 18, 19: keep wires short, max. 1.0 m
** leads 7, 8, 9, 10: keep wires short, max. 0.5 m
leads 14, 15, 16, 17: max. 2.0 m

PCA T5 EXCEL one4all Ip xitec 4x14/24 W

Dimmable ballasts from Tridonic have to be earthed.

RFI

- Connection to the lamps of the hot leads must be kept as short as possible
- Mains leads should be kept apart from lamp leads (ideally 5–10 cm distance)
- Do not run mains leads adjacent to the electronic ballast
- Twist the lamp leads
- Keep the distance of lamp leads from the metal work as large as possible
- Mains wiring to be twisted when through wiring
- Keep the mains leads inside the luminaire as short as possible

General advise

Electronic ballasts are virtually noise free. Magnetic fields generated during the ignition cycle can cause some background noise but only for a few milliseconds.

Operation on DC voltage

Our ballasts are construed to operate DC voltage and pulsed DC voltage. To operate ballasts with pulsed DC voltage the polarity is absolute mandatory.

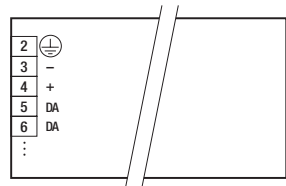

Programming

With appropriate software and a USB interface different functions can be activated and various parameters can be configured in the new PCA T5 EXCEL one4all Ip xitec. All that is needed is a DALI-USB and the software.

configTOOL

Full version for programming all the functions and parameters.

pcaCONFIGURATOR

For programming the corridorFUNCTION, device configuration (fade time, ePowerOnLevel, etc.) DC level, compatibility settings, and startup date and for resetting.

corridorFUNCTION CONFIGURATOR

For activating and deactivating the corridorFUNCTION and for project-specific programming of the PCA T5 EXCEL one4all Ip xitec units.

Isolation and electric strength testing of luminaires

Electronic devices can be damaged by high voltage. This has to be considered during the routine testing of the luminaires in production.

According to IEC 60598-1 Annex Q (informative only!) or ENEC 303-Annex A, each luminaire should be submitted to an isolation test with 500 V DC for 1 second. This test voltage should be connected between the interconnected phase and neutral terminals and the earth terminal.

The isolation resistance must be at least 2 MΩ.

As an alternative, IEC 60598-1 Annex Q describes a test of the electrical strength with 1500 V AC (or 1.414 x 1500 V DC). To avoid damage to the electronic devices this test must not be conducted.

① For further technical information please visit www.tridonic.com

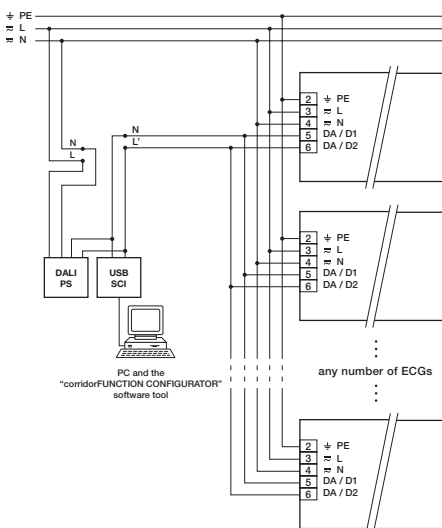

Wiring diagram for programming